

FLOREO AT TERAVALIS

PARCEL 48 GRADING PLAN

BUCKEYE, ARIZONA

LOCATED IN A PORTION OF THE WEST HALF OF SECTION 18, TOWNSHIP 3 NORTH, RANGE 4 WEST OF THE GILA AND SALT RIVER BASE AND MERIDIAN, MARICOPA COUNTY, ARIZONA

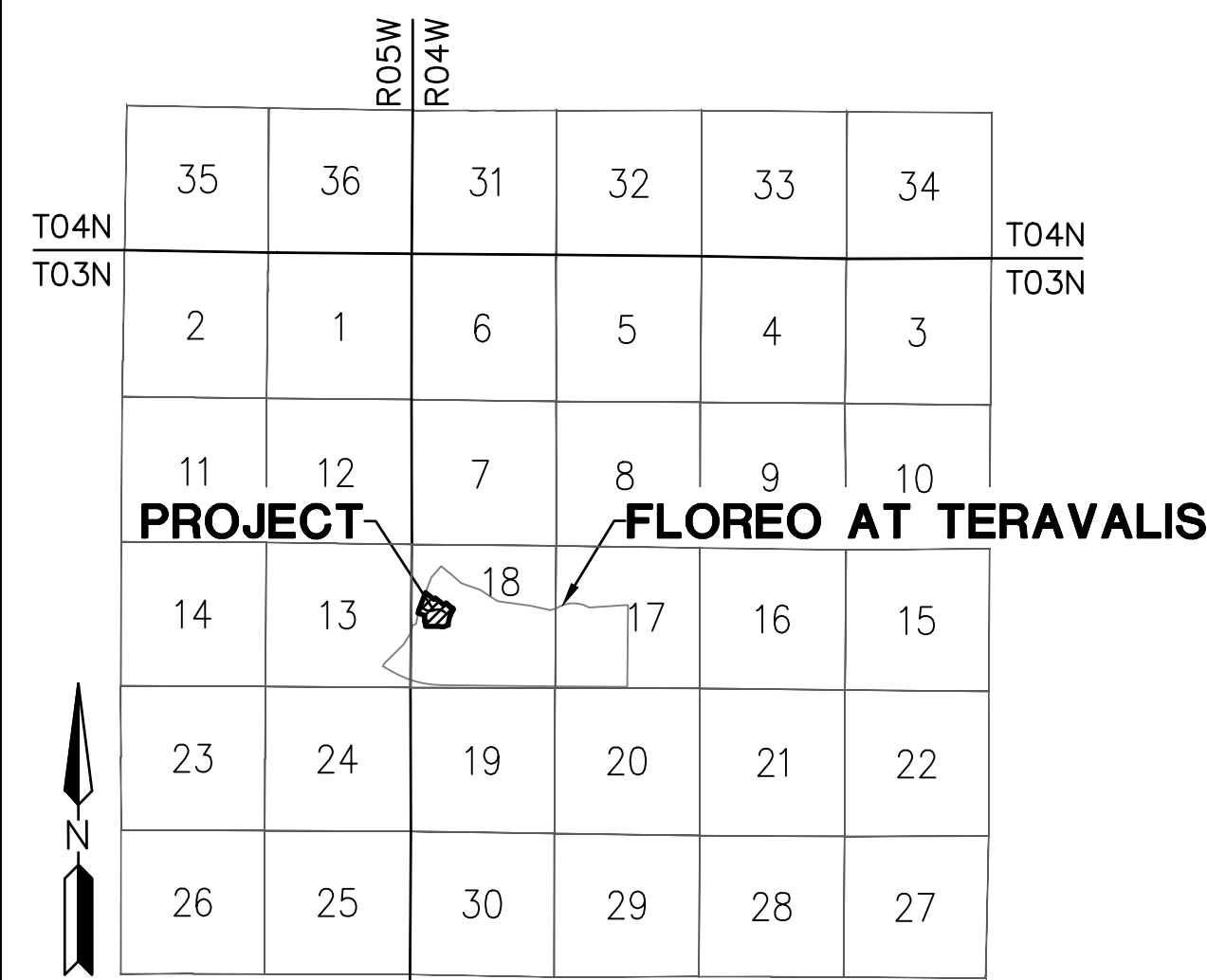
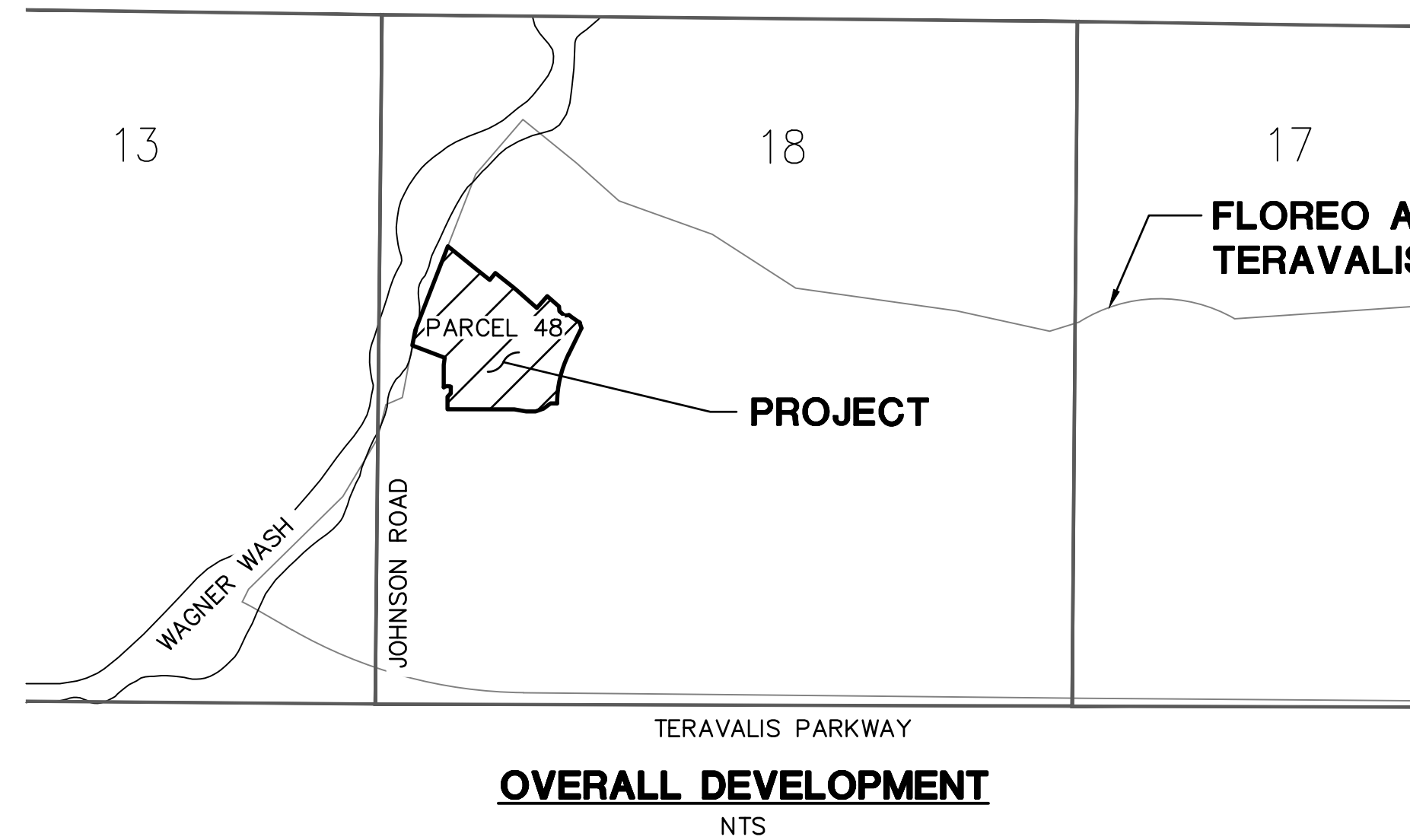

VICINITY MAP
NTS

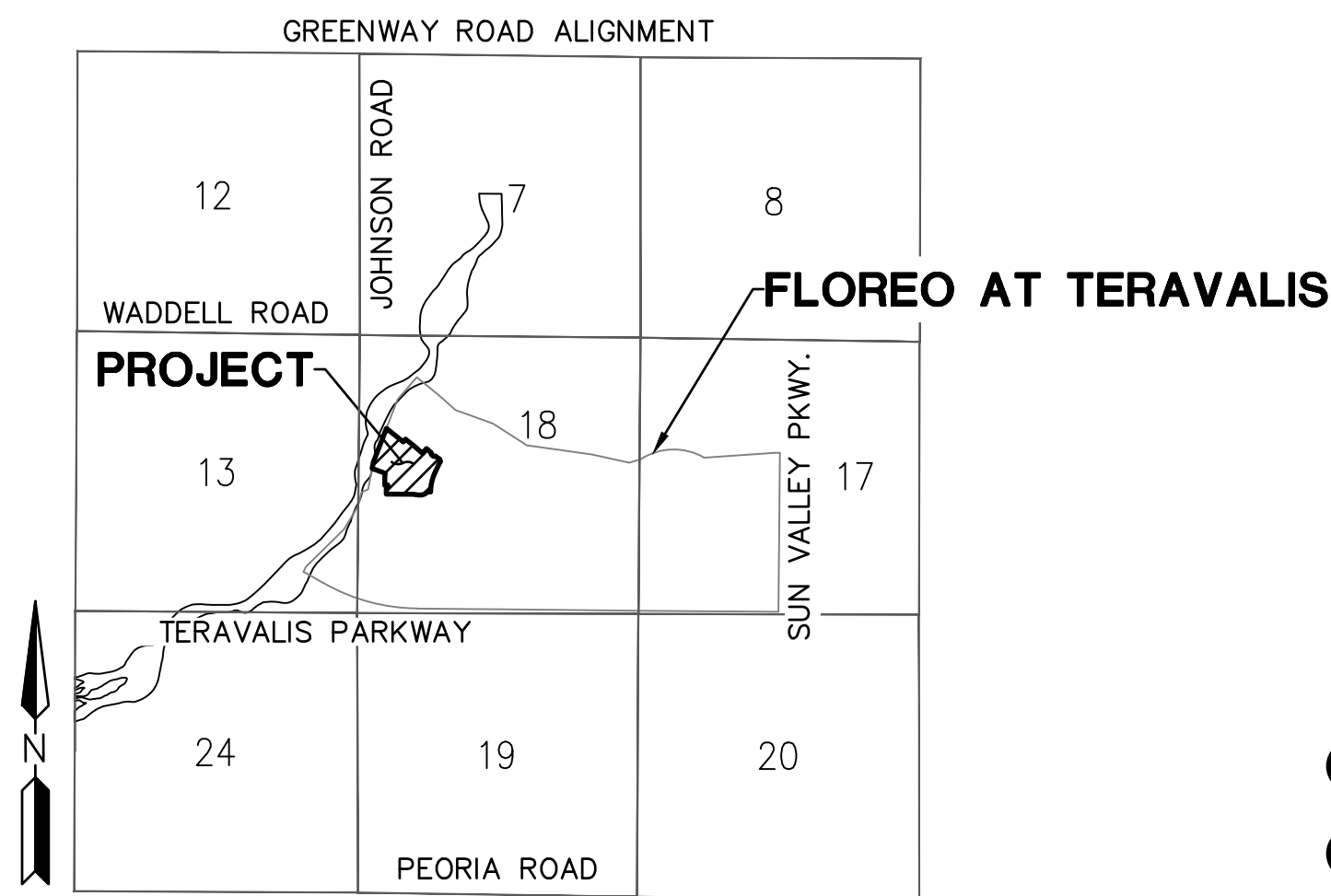

LOCATION MAP
NTS

GENERAL PERMITTING NOTES

- ALL CONSTRUCTION IN THE PUBLIC RIGHTS-OF-WAY OR IN EASEMENTS GRANTED FOR PUBLIC USE MUST CONFORM TO THE LATEST MARICOPA ASSOCIATION OF GOVERNMENTS (MAG) UNIFORM STANDARD SPECIFICATIONS AND UNIFORM STANDARD DETAILS FOR PUBLIC WORKS CONSTRUCTION AS AMENDED BY THE LATEST VERSION OF THE CITY OF BUCKEYE DESIGN STANDARDS. IF THERE IS A CONFLICT, THE CITY OF BUCKEYE STANDARDS WILL GOVERN.
- THE APPROVAL OF THE PLANS IS VALID FOR ONE (1) YEAR FROM THE DATE OF THE CITY ENGINEER'S SIGNATURE. IF AN ENCROACHMENT PERMIT FOR THE CONSTRUCTION HAS NOT BEEN ISSUED WITHIN ONE (1) YEAR, THE PLANS MUST BE RESUBMITTED TO THE CITY FOR REAPPROVAL.
- A CITY OF BUCKEYE INSPECTOR WILL INSPECT ALL WORKS WITHIN THE CITY OF BUCKEYE RIGHTS-OF-WAY AND IN EASEMENTS. NOTIFY THE CITY 24 HOURS PRIOR TO THE INSPECTION BY CALLING (623) 349-6248.
- CITY PERMITS ARE REQUIRED FOR ALL WORK IN PUBLIC RIGHTS-OF-WAY AND EASEMENTS GRANTED FOR PUBLIC PURPOSES. A CITY PERMIT WILL BE ISSUED BY THE CITY ONLY AFTER ALL FEES HAVE BEEN PAID AND THE PERMIT HAS AN APPROVED MARICOPA COUNTY ENVIRONMENTAL SERVICES DUST PERMIT AND AN APPROVED STORM WATER POLLUTION PREVENTION PLAN ATTACHED. THE SWPPP SHALL COMPLY WITH ALL FEDERAL, STATE, AND LOCAL REQUIREMENTS.
- COPIES OF ALL PERMITS AND MOST RECENT APPROVED PLANS MUST BE RETAINED ON-SITE AND BE AVAILABLE FOR INSPECTION AT ALL TIMES. FAILURE TO PRODUCE THE REQUIRED PERMITS AND PLANS WILL RESULT IN IMMEDIATE SUSPENSION OF ALL WORK UNTIL PROPER PERMIT DOCUMENTATION AND/OR PLANS ARE OBTAINED. ALL OF THESE REQUIREMENTS APPLY TO ONSITE GRADING AND IMPROVEMENT PLANS.

ENGINEER'S ESTIMATED QUANTITIES

ENGINEER'S QUANTITIES ARE FOR ESTIMATING PURPOSES ONLY, NOT FOR BIDDING PURPOSES. CONTRACTOR SHALL BASE THEIR BID ON THEIR OWN QUANTITY TAKEOFFS. ENGINEER MAKES NO GUARANTEE OF ACCURACY.

PAVING CONSTRUCTION NOTES

- 19 ADJUST MANHOLE FRAME & COVER PER MAG STD DTL 422 AND COB DTL 41260. 4 EA
- 40 CONSTRUCT 5' PRIVATE LANDSCAPE SIDEWALK PER MAG STD DTL 230. 2945 SF
- 52 CONSTRUCT 10' PRIVATE LANDSCAPE SIDEWALK PER MAG STD DTL 230. 4620 SF

GRADING CONSTRUCTION NOTES

- 1 CONSTRUCT TWO CHAMBER DRYWELL; DETAIL PER COB STD DTL B-501. RIM ELEVATION 0.3FT ABOVE BASIN BOTTOM. A MINIMUM OF 20' FROM HEADWALL, LOCATION NOTED IS TO CENTER OF INTERCEPTOR. 2 EA
- 2 CONSTRUCT RETAINING WALL. ELEVATION SHOWN ON PLANS. REFER TO STRUCTURAL PLAN BY OTHERS. 3496 LF
- 22 STEP RETAINING WALL PER RETAINING WALL STEP DETAIL SHEET DT04. 11 EA
- 23 PLACE LOOSE ANGULAR LAUNCHABLE RIP-RAP PER MAG SPEC SECTION 220; D50=12", ON 6" THICK GRANULAR, ANGULAR, CRUSHED STONE BEDDING. SEE DETAIL Q ON DT04. 1789 SY

ENGINEER'S ESTIMATED EARTHWORK QUANTITIES

GROSS CUT	1,251 C.Y.
GROSS FILL	119,034 C.Y.
SHRINKAGE LOSS (ASSUME 15%)	188 C.Y.
ADJUSTED NET EARTHWORK QUANTITY (IMPORT)	117,971 C.Y.

- EARTHWORK QUANTITIES ARE ESTIMATED VOLUMES BASED ON RAW VOLUMES. THE CONTRACTOR SHALL PREPARE THEIR OWN EARTHWORK ANALYSIS FOR BIDDING PURPOSES.
- EARTHWORK QUANTITIES DO NOT INCLUDE TEMPORARY RETENTION BASINS.

FLOREO AT TERAVALIS, CONSISTING OF 7 MIXED USE/COMMERCIAL/HIGH DENSITY PARCELS, 13 RESIDENTIAL PARCELS, COLLECTORS, ARTERIALS, & PARKWAYS, WILL BE GRADED AT ONE TIME AND UNDER THE MASS GRADING PERMIT. SEE MASS GRADING PLAN FOR OVERALL EARTHWORK QUANTITIES.

ENGINEER

HILGARTWILSON, LLC
2141 E. HIGHLAND AVENUE SUITE 250
PHOENIX, AZ 85016
PHONE: (602) 490-0535
FAX: (602) 368-2436
CONTACT: DAVID GEORGE
EMAIL: DGEORGE@HILGARTWILSON.COM

LANDSCAPE ARCHITECT

ABLA
310 E. RIO SALADO PKWY
TEMPE, AZ 85281
PHONE: (480) 530-0077
CONTACT: BRIAN ROGERS
EMAIL: BRIAN.ROGERS@ABLASTUDIO.COM

SHEET INDEX

SHT 1	CV01	COVER SHEET
SHT 2	DT01	KEY MAP & LEGEND
SHT 3-5	DT02-04	NOTES & DETAILS
SHT 6-8	GD01-03	GRADING PLAN

OWNER/DEVELOPER

TRILLIUM LAND COMPANY, LLC
9950 WOODLOCH FOREST DRIVE, SUITE 1100
THE WOODLANDS, TX 77380
CONTACT: HEATH MELTON
PHONE: (281) 716-6142
EMAIL: HEATH.MELTON@HOWARDHUGHES.COM
CONTACT: BRAD HINTON
PHONE: (602) 955-2424
EMAIL: BHINTON@ELDORADOHOLDINGS.NET

BASIS OF BEARING

N89°24'50"W ALONG THE SOUTH LINE OF THE SOUTHEAST QUARTER OF SECTION 18, TOWNSHIP 3 NORTH, RANGE 4 WEST OF THE GILA AND SALT RIVER BASE AND MERIDIAN, MARICOPA COUNTY, ARIZONA.

BENCHMARK

FOUND 1/2" STEEL ROD STAMPED "NGS 4FH3"
ELEVATION: 1565.486
DATUM: NAVD88

APPROVALS

DISCLAIMER:

THE CITY APPROVES THESE PLANS FOR CONCEPT ONLY AND ACCEPTS NO LIABILITY FOR ERRORS AND OMISSIONS.

BY: _____ DATE _____
BUCKEYE CITY ENGINEER

BY: LETTER NOVEMBER 10, 2022
CENTRAL ARIZONA PROJECT - CAWSD# 2022-156 DATE

AS-BUILT CERTIFICATION

I HEREBY CERTIFY THAT THE "AS - BUILT" INFORMATION SHOWN HEREON WAS OBTAINED UNDER MY DIRECT SUPERVISION AND IS CORRECT AND COMPLETE TO THE BEST OF MY KNOWLEDGE AND BELIEF.

ARIZONA REGISTERED LAND SURVEYOR/P.E. DATE _____

ARIZONA REGISTRATION NUMBER _____

TELEPHONE NUMBER _____

FEMA FLOOD ZONE DESIGNATION

COMMUNITY NUMBER	PANEL # PANEL DATE	SUFFIX	DATE OF FIRM (INDEX DATE)	FIRM ZONE
040039	1605 10/16/2013	L	OCT 16, 2013	AE, A, X

NET ACREAGE AND TOTAL DISTURBED AREA

TOTAL DISTURBED AREA	19.504 AC
NET AREA	22.752 AC

STORM WATER DRAINAGE CERTIFICATE

- THE DEVELOPMENT WILL PROVIDE FOR ON-SITE RETENTION FOR THE RUNOFF FROM A 100-YEAR 2-HOUR STORM.
- ALL FLOWS FROM THE 10-YEAR STORM WILL BE CONTAINED WITHIN THE STREET (FROM CURB TO CURB).
- ALL STORM WATER RETENTION WILL BE DRAINED WITHIN 36-HOURS. IF BASINS DO NOT DRAIN WITHIN 36-HOURS, DEVELOPER/OWNER SHALL ENACT MEASURES TO CORRECT.
- ALL DRAINAGE DESIGN WILL COMPLY WITH THE CITY OF BUCKEYE CURRENT GRADING AND DRAINAGE DESIGN STANDARDS.
- FINISH FLOOR ELEVATIONS MUST BE A MINIMUM OF 14-INCHES ABOVE THE OUTFALL TOP OF CURB ELEVATION AND 12-INCHES ABOVE THE COMPUTED 100-YEAR WATER ELEVATIONS AND 1-FOOT ABOVE THE EMERGENCY OUTFALL ELEVATIONS AT ANY ADJACENT RETENTION BASIN, WHICH EVER IS GREATER.
- ALL RETENTION BASINS SHALL HAVE A MINIMUM OF 1-FOOT OF FREEBOARD.

BY: *David W. George* 11/17/22 DATE _____
REGISTERED CIVIL ENGINEER

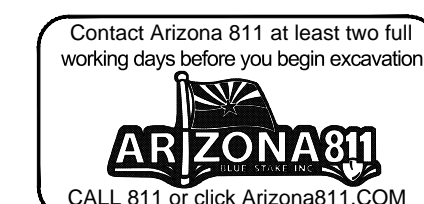

MANAGING ENGINEERING / SURVEYOR HILGARTWILSON	PROJECT COORDINATOR SANDY HAYDEN	CHECKED JR	CHECKED	AS SHOWN										
DESIGN LAYOUT MD	FIELD SURVEY	DRAFTED JM	DRAFTED											
DRAWING SCALES														
GRADING PLAN														
 HILGARTWILSON ENGINEER PLAN SURVEY MANAGE 2141 E. HIGHLAND AVE., STE. 250 P. 602.490.0535 / F. 602.368.2436 PHOENIX, AZ 85016 WWW.HILGARTWILSON.COM														
FLOREO AT TERAVALIS PARCEL 48 NORTHEAST CORNER OF TERAVALIS PARKWAY & SUN VALLEY PARKWAY BUCKEYE, ARIZONA COB PROJECT PLAN STICKER														
REVISIONS:														
<table border="1" style="width: 100%; border-collapse: collapse;"> <tr> <td style="width: 15%;">COB PERMITTING APPROVED SEAL</td> <td style="width: 15%;">COB ENGINEERING APPROVED SEAL</td> <td style="width: 10%;"></td> <td style="width: 10%;"></td> <td style="width: 10%;"></td> </tr> <tr> <td colspan="2" style="text-align: center;"> </td> <td colspan="3" style="text-align: center;"> SUBMITTAL: ENG-21-0595 COB PERMIT # </td> </tr> </table>					COB PERMITTING APPROVED SEAL	COB ENGINEERING APPROVED SEAL						SUBMITTAL: ENG-21-0595 COB PERMIT #		
COB PERMITTING APPROVED SEAL	COB ENGINEERING APPROVED SEAL													
		SUBMITTAL: ENG-21-0595 COB PERMIT #												
AS-BUILT SEAL		DESIGN SEAL												
ORIGINAL PLAN DATE NOV 2022		LATEST REVISION DATE												
PROJECT NUMBER 1175		SHEET NUMBER CV01 1 OF 8												

CITY OF BUCKEYE GENERAL CONSTRUCTION NOTES

- CITY OF BUCKEYE BUILDING DEPARTMENT SHALL BE NOTIFIED 24 HOURS IN ADVANCE OF ANY ON-SITE OR OFF-SITE CONSTRUCTION. PHONE 602-349-6248 FOR THE HOTLINE. ALL OTHERS FAX THE INSPECTION REQUEST FORM TO 623-349-6221, OR USE THE WEB BASED PERMIT PORTHOLE ACCESS TO SCHEDULE AN INSPECTION (WWW.BUCKEYEAZ.GOV).
- ALL WORK AND MATERIALS MUST CONFORM WITH THESE SPECIFICATIONS, THE CURRENT UNIFORM STANDARD SPECIFICATIONS AND DETAILS FOR PUBLIC WORKS CONSTRUCTION AS SPONSORED AND DISTRIBUTED BY THE MARICOPA ASSOCIATION OF GOVERNMENTS (M.A.G.) AND AS AMENDED BY THE CITY OF BUCKEYE (COB).
- A PERMIT IS REQUIRED FROM THE COB FOR ALL CONSTRUCTION WITHIN THE RIGHTS-OF-WAY (ROW).
- THE CONTRACTOR WILL EXPOSE ALL EXISTING UTILITY LINES BEING TIED IN TO VERIFY THEIR LOCATION.
- THE CONTRACTOR WILL LOCATE, OR HAVE LOCATED, ALL EXISTING UNDERGROUND UTILITIES (ELECTRIC, TELEPHONE, PIPELINE, ETC.) AND STRUCTURES IN ADVANCE OF CONSTRUCTION AND WILL ELIMINATE ALL CONFLICTS PRIOR TO START OF CONSTRUCTION.
- THE CONTRACTOR IS RESPONSIBLE TO CALL BLUE STAKE PRIOR TO STARTING ANY CONSTRUCTION. NO WORK SHALL BEGIN UNTIL BLUE STAKE IS COMPLETED. BLUE STAKE TELEPHONE NUMBER 602-263-1100 OR 1-800-STAKE-IT.
- A PRE-CONSTRUCTION MEETING IS REQUIRED PRIOR TO STARTING ANY WORK OR NEW PHASE OF WORK. THE CONTRACTOR, KEY SUB-CONTRACTORS, COB INSPECTOR AND REPRESENTATIVE OF THE CITY ENGINEER SHALL ATTEND THIS MEETING.
- ANY WORK PERFORMED WITHOUT THE APPROVAL OF THE COB AND/OR ALL WORK AND MATERIAL NOT IN CONFORMANCE WITH THE SPECIFICATIONS IS SUBJECT TO REMOVAL AND REPLACEMENT AT THE CONTRACTOR'S EXPENSE.
- DISPOSAL OF EXCESS MATERIAL WITHOUT A PERMIT WITHIN THE COB LIMITS IS PROHIBITED. A USE PERMIT IS REQUIRED FOR DISPOSAL OR STOCKPILING OF MATERIALS WITHIN A RESIDENTIAL AREA. STOCKPILING OF EXCAVATED MATERIAL SHALL NOT EXCEED A HEIGHT OF 6 FEET ABOVE THE NATURAL GROUND ELEVATION. THE SLOPES ON ALL SIDES OF THE STOCKPILED EXCAVATED MATERIAL SHALL NOT EXCEED A 4:1 RATIO OF LENGTH TO HEIGHT.
- EXCAVATION CONTRACTORS MUST IDENTIFY LOCATION FOR DISPOSING OF EXCESS EXCAVATION MATERIAL ALONG WITH A LETTER FROM THE LAND OWNER, GIVING PERMISSION FOR DUMPING PRIOR TO STARTING ANY CONSTRUCTION.
- TRAFFIC CONTROL SHALL BE PROVIDED AND MAINTAINED IN ACCORDANCE WITH THE LATEST EDITION OF THE MANUAL OF UNIFORM TRAFFIC CONTROL DEVICES AND THE CITY OF PHOENIX BARRICADING MANUAL/MARICOPA COUNTY DEPARTMENT OF TRANSPORTATION M.A.G. UNIFORM STANDARD DETAIL 401, AND COB REQUIREMENTS. THE CONTRACTOR IS REQUIRED TO SUBMIT A TRAFFIC CONTROL PLAN AND BARRICADE PLAN TO THE COB FOR APPROVAL WHERE THE CONSTRUCTION OF THE NEW IMPROVEMENTS ARE ADJACENT TO OR CONNECTING TO ANY EXISTING ROADWAY OR PEDESTRIAN FACILITIES. THE TRAFFIC CONTROL PLAN AND BARRICADE PLAN SHALL BE APPROVED BEFORE A PERMIT FOR THE WORK WILL BE ISSUED. THE CONTRACTOR SHALL INSTALL APPROVED BARRICADING AND TRAFFIC CONTROL AS APPROVED BY THE COB, BEFORE WORK CAN TAKE PLACE. ALL OVERNIGHT BARRICADES SHALL BE LIT AND FUNCTIONING.
- A HAUL PLAN FOR MATERIAL IMPORT OR EXPORT SHALL BE REQUIRED FOR COB REVIEW AND APPROVAL PRIOR TO THE START OF HAULING. THE CONTRACTOR SHALL BE RESPONSIBLE FOR DAILY AND FINAL CLEAN-UP OPERATION OF ADJACENT, EXISTING PAVED STREETS USED BY CONSTRUCTION TRAFFIC. THIS WORK INCLUDES STREET SWEEPING, POWER BROOM AND WATER AS NEEDED OR DIRECTED BY THE COB.
- ENVIRONMENTAL REQUIREMENTS
 - THE CONTRACTOR SHALL BE RESPONSIBLE FOR DUST CONTROL RELATED TO THE PROJECT CONSTRUCTION AND SHALL TAKE WHATEVER MEANS NECESSARY TO CONTROL ANY ABNORMAL CONDITIONS.
 - THE CONTRACTOR SHALL PROVIDE ADEQUATE MEANS FOR CLEANING TRUCKS AND/OR OTHER EQUIPMENT OF MUD PRIOR TO ENTERING PUBLIC STREETS, AND TAKE WHATEVER MEASURES ARE NECESSARY TO INSURE THAT ALL ROADS ARE MAINTAINED IN A CLEAN, MUD AND DUST FREE CONDITION AT ALL TIMES.
 - THE CONTRACTOR SHALL BE RESPONSIBLE FOR DAILY AND FINAL CLEAN-UP OPERATIONS OF ADJACENT, EXISTING PAVED STREETS USED BY CONSTRUCTION TRAFFIC.
 - TEMPORARY DRAINAGE CONTROL MEASURES MAY BE REQUIRED DURING AND AFTER CONSTRUCTION UNTIL FINAL PROJECT BUILD-OUT IN ACCORDANCE WITH THE APPROVED PLANS AND IN ACCORDANCE WITH ANY ESTABLISHED OR REQUIRED BEST MANAGEMENT PRACTICES (BMP) AS PART OF THE NATIONAL POLLUTION DISCHARGE ELIMINATION SYSTEM (NPDES) PERMIT REQUIREMENTS. IT IS THE CONTRACTOR'S RESPONSIBILITY TO MEET ALL REQUIREMENTS.
 - THE CONTRACTOR IS RESPONSIBLE TO OBTAIN ALL AIR QUALITY PERMITS.
 - THE CONTRACTOR SHALL SUBMIT TO THE COB A COPY OF THEIR APPROVED COUNTY (AIR QUALITY) DUST CONTROL PLAN, EROSION CONTROL PLAN (SWPPP), AND PERMIT PRIOR TO THE START OF WORK.
- STREET CUTS: APPLICATIONS FOR STREET CUT PERMITS MUST BE APPROVED BY THE CITY ENGINEER PRIOR TO APPROVAL OF PLANS. THE PAVEMENT REPLACEMENT SECTION FOR ALL LONGITUDINAL AND TRANSVERSE TRENCHES LOCATED IN AN EXISTING PAVED STREET SHALL BE CONSTRUCTED IN ACCORDANCE M.A.G. UNIFORM STANDARD DETAIL NO.200 "T"-TOP BACKFILL PAVEMENT SURFACE REPLACEMENT, MODIFIED AS FOLLOWS: THE WIDTH OF THE REPLACED PAVEMENT SECTION EXTEND 1 FOOT BEYOND THE TRENCH SIDE EDGE LINE, ON EITHER SIDE OF THE TRENCH. THE DEPTH OF THE PERMANENT SURFACE REPLACEMENT SHALL BE A MINIMUM OF 3 INCHES OR MATCH THE EXISTING THICKNESS OF THE PAVEMENT, WHICHEVER IS GREATER; SAWCUT OR CONSTRUCTION JOINTS SHALL BE PROPERLY TACK OILED WITH A MINIMUM OF 95% COVERAGE. ASPHALT MATERIAL SHALL BE COB APPROVED MIX DESIGN WITH COMPACTED LIFTS NO GREATER THAN 3 INCHES. SLURRY BACKFILLED OR OPEN TRENCHES EXISTING ROADWAYS MUST BE PROPERLY STEEL PLATED AND BARRICADED OVER NIGHT. STEEL PLATES TO BE MILLED :FLUSH WITH ROADWAY SURFACE PER NOTE 24. "COLD MIX" TEMPORARY ASPHALT PATCHES MUST BE REPLACED AS SOON AS POSSIBLE AND CANNOT REMAIN FOR MORE THAN 5 DAYS TIME OR AS REQUIRED BY THE COB. DURING THE 5 DAY PERIOD THE CONTRACTOR IS REQUIRED TO MAINTAIN THE PATCH TO WITHIN MAG STD SPEC 321.5.3. ASPHALT IN PLACE FOR LESS THAN 5 YEARS SHALL BE MILLED AND OVERLAYED A MINIMUM OF 20 FEET PAST TRENCH WALLS, AND IN THE CASE OF MULTIPLE STREET CUTS, THE CONTINUOUS MILL AND OVERLAY SHALL EXTEND A MINIMUM OF 2 FEET PAST END OF THE FURTHEST TRENCH WALLS.
- POTHOLING: NO POTHOLING SHALL BE DONE ON ANY STREET NEWER THAN 2 YEARS OLD. ALL POTHOLING IN EXISTING STREETS SHALL BE DONE USING WATER/AIR/VACUUM TYPE METHOD. POTHOLE SIZE SHALL BE LIMITED TO A 12 INCH BY 12 INCH SQUARE HOLE. REMOVAL MATERIAL CANNOT BE USED FOR BACK FILL. THE CONTRACTOR SHALL USE SLURRY PER MAG SEC.728. PAVEMENT REPLACEMENT SHALL BE BY APPROVED HOT MIX ASPHALT ONLY. A 3 FOOT BY 3 FOOT PAVEMENT SLURRY SEAL SHALL BE APPLIED AFTER THE ASPHALT IS PLACED.
- AN APPROVED, UP-TO-DATE SET OF PLANS AND A RIGHT-OF-WAY PERMIT SHALL BE MAINTAINED ON THE JOB SITE AT ALL TIMES WHILE WORK IS IN PROGRESS. IF THE PLANS AND PERMITS ARE NOT ON SITE, THE WORK SHALL BE STOPPED UNTIL THE APPROVED PLANS ARE PROVIDED. DEVIATION FROM THE PLANS SHALL NOT BE ALLOWED WITHOUT THE COB'S APPROVAL.
- DAMAGE TO ANY AND ALL ITEMS CAUSED BY CONSTRUCTION OR CONSTRUCTION RELATED WORK SHALL BE REPLACED OR REPAIRED TO THE SAME OR BETTER CONDITION AT THE CONTRACTOR'S EXPENSE.
- ALL PARCEL CONSTRUCTION ACCESS LOCATIONS ARE SUBJECT TO THE CITY ENGINEER'S APPROVAL. THE CONTRACTOR SHALL BE RESPONSIBLE FOR MAINTAINING PROPER AND ADEQUATE ACCESS ROADS INSIDE AND THROUGHOUT THE PARCEL ALLOWING FOR INSPECTION ACCESSIBILITY. THIS INCLUDES GRADING, GRAVEL FILL AND/OR TRENCH PLATES AS REQUIRED.
- THE CONTRACTOR AGREES TO ASSUME SOLE AND COMPLETE RESPONSIBILITY FOR JOB SITE CONDITIONS DURING THE COURSE OF CONSTRUCTION OF THIS PROJECT INCLUDING SAFETY OF ALL PERSONS AND PROPERTY. THIS REQUIREMENT SHALL APPLY CONTINUOUSLY NOT BE LIMITED TO NORMAL WORKING HOURS. THE CONTRACTOR SHALL DEFEND, INDEMNIFY AND HOLD THE COB AND THE COB CONSULTANT & HARMLESS FROM ANY AND ALL LIABILITY, REAL OR ALLEGED, IN CONNECTION WITH THE PERFORMANCE OF WORK ON THIS PROJECT, EXCEPTING FOR LIABILITY ARISING FROM THE SOLE NEGLIGENCE OF THE COB.

- THE COB SHALL NOT BE RESPONSIBLE FOR CONSTRUCTION MEANS, METHODS, TECHNIQUES, SEQUENCES OR PROCEDURES UTILIZED IN CONNECTION WITH THE WORK. THE COB WILL NOT BE RESPONSIBLE FOR THE CONTRACTOR'S FAILURE TO CARRY OUT THE WORK IN ACCORDANCE WITH THE CONTRACT DOCUMENTS COMPLYING WITH MAG OR COB REQUIREMENTS.
- THE CONTRACTOR SHALL BE RESPONSIBLE FOR SUBMITTING CERTIFIED AS-BUILT RECORD DOCUMENT & TO THE COB FOR REVIEW AND APPROVAL. NO FINAL ACCEPTANCE SHALL BE ISSUED UNTIL "AS-BUILT" PLANS CERTIFIED BY THE PROJECT ENGINEER/LAND SURVEYOR HAVE BEEN SUBMITTED AND ACCEPTED BY THE COB. FINAL CONSTRUCTION ACCEPTANCE OR THE RELEASE OF CERTIFICATE OF OCCUPANCIES SHALL NOT BE ISSUED UNTIL ALL AS-BUILT DRAWINGS AND OTHER REQUIRED DOCUMENTS PER THE COB'S FINAL PROJECT SUBMITTAL CHECKLIST HAVE BEEN REVIEWED AND APPROVED BY THE CITY ENGINEER.
- ARRANGEMENTS FOR CONSTRUCTION WATER CAN BE MADE BY CALLING THE WATER RESOURCE DEPARTMENT AT (623) 349-6800.
- THE COB IS NOT RESPONSIBLE FOR LIABILITY ACCRUED DUE TO DELAYS AND/OR DAMAGES TO UTILITIES IN CONJUNCTION WITH THIS CONSTRUCTION. ALSO, THE CITY WILL NOT PARTICIPATE IN THE COST OF CONSTRUCTION OR RELOCATION OF UTILITIES.
- ALL CONTRACTORS SHALL CONTRACT FOR TRASH PICKUP THROUGH A LICENSED CITY OF BUCKEYE SOLID WASTE HAULER (602-237-2078) AND DISPOSED OF AT THE SOUTHWEST REGIONAL LANDFILL IN BUCKEYE.
- OPEN TRENCHES ACROSS DRIVEWAYS, STREETS AND CROSS-STREETS SHALL BE PLATED FOR OVERNIGHT, WEEKEND OR EXTENDED PERIODS, PER M.A.G. UNIFORM STANDARD DETAIL 211.
- ALL ABC SHALL BE FROM AN ARIZONA DEPARTMENT OF TRANSPORTATION (ADOT) APPROVED SOURCE LIST.
- LONGITUDINAL TRENCH BACKFILL IN EXISTING ARTERIAL, COLLECTOR, OR LOCAL ROADWAYS OR ADJACENT TO EXISTING ROADWAY (WHEN THE TRENCH EXCAVATION FALLS WITHIN 2 FEET OF EDGE OF PAVEMENT) SHALL REQUIRE ¾ SACK CLSM PER MAG SPEC 728 FULL DEPTH OR ABC FULL DEPTH AS DIRECTED BY THE COB. ABC BACKFILL COMPACTION SHALL BE BY AN APPROVED MECHANICAL METHOD (NO WATER SETTLING) WITH BACKFILL MATERIAL LIST AS FOLLOWS:
 - 12 INCH LIFTS (LOOSE) TO BE USED IN THE TOP 4 FEET OF THE TRENCH
 - 24 INCH LIFTS (LOOSE) TO BE USED FROM 1 FOOT OVER THE PIPE TO 4 FEET FROM THE TOP OF THE TRENCH PER MAG SEC.601.4.
- ALL BACKFILL WITHIN OR ADJACENT TO EXISTING ROADWAYS SHALL BE MECHANICALLY COMPACTED.
- TRANSVERSE TRENCH BACKFILL IN ALL EXISTING ROADWAYS SHALL REQUIRE 100% FULL DEPTH HALF SACK CLSM PER MAG SPEC 728.
- ALL MATERIAL SUBMITTALS INCORPORATED IN THE PROJECT SHALL BE SUBMITTED AT OR BEFORE THE PRE-CONSTRUCTION MEETING FOR REVIEW AND APPROVAL BY THE CITY ENGINEER.

CITY OF BUCKEYE GRADING CONSTRUCTION NOTES

- ALL DESIGN AND CONSTRUCTION MUST BE IN ACCORDANCE WITH THE UNIFORM STANDARD SPECIFICATIONS AND DETAILS FOR PUBLIC WORKS CONSTRUCTION PUBLISHED BY THE MARICOPA ASSOCIATION OF GOVERNMENTS (MAG) EXCEPT AS AMENDED BY THE CITY OF BUCKEYE STANDARD CONSTRUCTION DETAILS. ALL IMPROVEMENTS WITHIN THE DEVELOPMENT INCLUDING OFFSITE IMPROVEMENTS SHALL BE IN ACCORDANCE WITH THE LATEST CITY OF BUCKEYE ENGINEERING DESIGN STANDARDS.
- NO GRADING SHALL BEGIN WITHOUT A PERMIT FROM THE CITY OF BUCKEYE.
- OFFSITE CONSTRUCTION REQUIRES A SEPARATE PERMIT BY THE CITY OF BUCKEYE.
- CONTRACTOR SHALL NOTIFY THE CITY OF BUCKEYE PUBLIC WORKS DEPARTMENT ASSIGNED INSPECTOR AT LEAST TWENTY-FOUR (24) HOURS IN ADVANCE OF ANY REQUIRED CONSTRUCTION INSPECTION.
- CONTRACTOR MUST CALL THE ARIZONA BLUE STAKE CENTER (602) 263-1100, FORTY-EIGHT (48) HOURS BEFORE DIGGING OR EXCAVATING FOR LOCATION OF ALL UNDERGROUND UTILITIES.
- IT IS THE RESPONSIBILITY OF THE DEVELOPER AND HIS/HER AGENT IN COORDINATING THE RELOCATION OF POWER POLES FROM THE APPLICABLE UTILITY COMPANY.
- NO MINIMUM FINISHED FLOOR ELEVATION SHALL BE ALTERED, UNLESS APPROVED BY PUBLIC WORKS AND THE DEVELOPER'S CIVIL ENGINEER.
- ALL STAKING INCLUDING FINISHED FLOOR ELEVATIONS IS THE SOLE RESPONSIBILITY OF THE DEVELOPER'S REGISTERED CIVIL ENGINEER AND LAND SURVEYOR. SUBMISSION OF CERTIFIED PAD ELEVATIONS IS REQUIRED PRIOR TO FINAL ACCEPTANCE.
- CONTRACTOR SHALL PROVIDE GRADING FOR POSITIVE DRAINAGE IN ALL RETENTION BASINS AT ELEVATIONS AS ABUTTING PUBLIC RIGHT OF WAY.
- DRYWELL INLET GRATE SHALL BE 0.30 FEET ABOVE FINISH GRADE AT BOTTOM ELEVATION OF THE RETENTION BASIN.
- DRILLING LOGS FOR DRYWELLS AT 5.0 FOOT INTERVALS INCLUDING LITHOLOGY CHANGES WILL BE FURNISHED TO THE CITY OF BUCKEYE PUBLIC WORKS DEPARTMENT PRIOR TO FINAL ACCEPTANCE.
- PERCOLATION TESTS WILL BE REQUIRED OF COMPLETED DRYWELLS PRIOR TO ACCEPTANCE. SHOULD EXISTING SOIL CONDITIONS BE ENCOUNTERED WHICH LACK SUFFICIENT PERCOLATION RATES, ADDITIONAL DRYWELLS OR AN ALTERNATE METHOD OF STORM WATER RUN-OFF DISPOSAL WILL BE REQUIRED. FINAL CERTIFIED PERCOLATION TEST RATES FROM ASTM D 3385 SHALL BE SUBMITTED AT THE TIME OF AS-BUILTS, WITH THE REQUIRED 50% REDUCTION FACTOR.
- DRYWELL CONSTRUCTION SHALL BE DONE ONLY BY A CONTRACTOR LICENSED BY THE ARIZONA DEPARTMENT OF ENVIRONMENTAL QUALITY WITH THE APPROVED REGISTRATION FOR EACH DRYWELL.
- THE APPROVED DRYWELL REGISTRATION SHALL BE SUBMITTED TO THE CITY BY THE DEVELOPER OR HIS/HER CIVIL ENGINEER AT THE TIME AS-BUILTS ARE SUBMITTED.
- CONTRACTOR SHALL COMPLY WITH THE PROVISIONS FOR WORK ZONE SAFETY AND TRAFFIC CONTROL PROTECTION AS INDICATED IN PART IV OF THE MANUAL ON UNIFORM TRAFFIC CONTROL DEVICES (MUTCD 2003 EDITION) AND WHERE APPLICABLE ACROSS JURISDICTIONAL AUTHORITIES BUT WITHIN THE CITY OF BUCKEYE, MCDOT, AND ADOT'S TRAFFIC CONTROL MANUAL FOR HIGHWAY CONSTRUCTION AND MAINTENANCE (MOST CURRENT EDITION).
- ALL RETENTION BASINS MUST DRAIN ANY STORM EVENT UP TO AND INCLUDING THE 100 YEAR 2 HOUR STORM WITHIN THIRTY-SIX (36) HOURS OF POST DEVELOPMENT CONSTRUCTION. OWNER(S) OF ANY BASIN FAILING TO MEET THIS REQUIREMENT MUST TAKE CORRECTIVE ACTION TO BRING THE BASIN INTO COMPLIANCE.
- THE CONTRACTOR SHALL NOT DISTURB EXISTING SURVEY MONUMENTS OR BENCHMARKS NOTED ON THE PLANS. REMOVAL AND REPLACEMENT SHALL BE DONE BY AN ARIZONA REGISTERED LAND SURVEYOR ONLY.
- THE CONTRACTOR SHALL HAVE SUFFICIENT MEANS TO PROVIDE DUST CONTROL. DUST SHALL BE CONTROLLED IN ACCORDANCE WITH THE MARICOPA COUNTY ENVIRONMENTAL SERVICES.
- PERIMETER WALL FENCES ARE REQUIRED TO BE COMPACTED NO LESS THAN 90% BY THE CONTRACTOR.
- ARRANGEMENTS FOR CONSTRUCTION WATER CAN BE MADE BY CALLING THE CITY OF BUCKEYE PUBLIC WORKS DEPARTMENT AT 623-349-6800.
- THE CONTRACTOR SHALL PROVIDE ADEQUATE MEANS FOR THE ELIMINATION OF MUD AND DUST ACCUMULATION IN PUBLIC STREETS BY TRUCKS LEAVING THE SITE (TRACK OUT DEVICES). PUBLIC RIGHT OF WAYS SHALL BE KEPT CLEAN AND FREE OF DEBRIS FROM CONSTRUCTION SITES.
- DISPOSAL OF EXCESS MATERIAL WITHIN THE CITY'S LIMITS IS PROHIBITED. A USE PERMIT IS REQUIRED FOR DISPOSAL AND/OR STOCKPILING MATERIALS WITHIN A RESIDENTIAL AREA.
- APPROVED CONSTRUCTION PLANS SHALL BE KEPT ON THE JOBSITE AT ALL TIMES. DEVIATION FROM THE PLANS IS NOT ACCEPTABLE UNLESS AN APPROVED PLAN REVISION HAS BEEN GRANTED BY PUBLIC WORKS DEPARTMENT.

CITY OF BUCKEYE NOTES

ALL CITY OF BUCKEYE GENERAL NOTES AND UTILITY NOTES ARE ACCESSIBLE ON THE CITY'S WEBSITE AT www.buckeyeaz.gov, UNLESS OTHERWISE ATTACHED.

HILGARTWILSON STANDARD ENGINEERING NOTES

- THESE PLANS ARE SUBJECT TO THE INTERPRETATION OF INTENT BY THE ENGINEER. ALL QUESTIONS REGARDING THESE PLANS SHALL BE PRESENTED TO THE ENGINEER. ANYONE WHO TAKES IT UPON THEMSELVES THE INTERPRETATION OF THE DRAWINGS OR MAKES REVISIONS TO THE SAME WITHOUT CONFERRING WITH THE DESIGN ENGINEER SHALL BE RESPONSIBLE FOR THE CONSEQUENCES THEREOF.
- THE ESTIMATED QUANTITIES SHOWN ARE FOR INFORMATION PURPOSES ONLY. THE CONTRACTOR SHALL BE RESPONSIBLE FOR THE COMPLETENESS AND ACCURACY OF A DETAILED ESTIMATE BASED ON THESE PLANS, CURRENT CODES, AND SITE VISITATION.
- ALL EARTHWORK CONSTRUCTION SHALL CONFORM TO THE LATEST MARICOPA ASSOCIATION OF GOVERNMENTS STANDARD DETAILS AND/OR SPECIFICATIONS INCLUDING ANY SUPPLEMENTS THERETO, AND ALL ADDENDA. THE CONTRACTOR IS TO FOLLOW THE RECOMMENDATION OF GEOTECH REPORT AS PREPARED BY ALPHA GEOTECHNICAL & MATERIAL, INC., PHONE NO. 602-453-3267, PROJECT NO. 20-G-11044, DATED FEBRUARY 9, 2021.
- PRIOR TO BIDDING THE WORK, THE CONTRACTOR SHALL THOROUGHLY SATISFY HIMSELF AS TO THE ACTUAL CONDITIONS, REQUIREMENTS OF THE WORK AND EXCESS OR DEFICIENCY IN QUANTITIES. NO CLAIMS SHALL BE MADE AGAINST THE OWNER/DEVELOPER OR ENGINEER FOR ANY EXCESS OR DEFICIENCY THEREIN, ACTUAL OR RELATIVE.
- THE ENGINEER SHALL NOT BE RESPONSIBLE FOR CONSTRUCTION MEANS, METHODS, TECHNIQUES, SEQUENCES, PROCEDURES OR SAFETY PRECAUTIONS OR PROGRAMS UTILIZED IN CONNECTION WITH THE WORK, AND WILL NOT BE RESPONSIBLE FOR THE CONTRACTOR'S FAILURE TO CARRY OUT THE WORK IN ACCORDANCE WITH THE CONTRACT DOCUMENTS.
- THE ENGINEER SHALL NOT BE RESPONSIBLE FOR COORDINATING THE RELOCATION OF UTILITIES, POWER POLES, ETC.
- THE CONTRACTOR SHALL MAKE NO CLAIM AGAINST THE OWNER OR THE SURVEYOR REGARDING ALLEGED INACCURACY OF CONSTRUCTION STAKES SET BY THE SURVEYOR UNLESS ALL SURVEY STAKES SET BY THE ENGINEER ARE MAINTAINED INTACT AND CAN BE VERIFIED AS TO THEIR ORIGIN. IF, IN THE OPINION OF THE SURVEYOR, THE STAKES ARE NOT MAINTAINED INTACT AND CANNOT BE VERIFIED AS TO THEIR ORIGIN, ANY REMEDIAL WORK REQUIRED TO CORRECT ANY ITEM OF IMPROPER CONSTRUCTION WORK SHALL BE PERFORMED AT THE SOLE EXPENSE OF THE RESPONSIBLE CONTRACTOR OR SUBCONTRACTOR.
- THE SURVEYOR WILL MAKE FIELD AS-BUILT MEASUREMENTS OF THE WORK UPON NOTIFICATION BY THE CLIENT OR HIS REPRESENTATIVE THAT THE WORK IS COMPLETE AND READY FOR AS-BUILT SURVEY. FOR PIPE WORK, THE CONTRACTOR IS RESPONSIBLE FOR LEAVING TRENCHES OPEN SO THAT AS-BUILTS CAN BE PERFORMED TO COMPLY WITH THE AGENCY'S REQUIREMENTS. (IF THE TRENCHES ARE BACKFILLED AND OBTURED TO THE POINT THAT AS-BUILT MEASUREMENTS CANNOT BE PERFORMED, IT WILL BE THE RESPONSIBILITY OF THE CONTRACTOR TO POTHOLE UTILITY TRENCHES AS NECESSARY TO COMPLETE AN AS-BUILT SURVEY.)
- THE CONTRACTOR IS TO VERIFY THE LOCATION, ELEVATION, CONDITION, AND PAVEMENT CROSS-SLOPE OF ALL EXISTING SURFACES AT POINTS OF TIE-IN AND MATCHING, PRIOR TO COMMENCEMENT OF GRADING, PAVING, CURB AND GUTTER OR OTHER SURFACE CONSTRUCTION. SHOULD EXISTING LOCATIONS, ELEVATIONS, CONDITIONS, OR PAVEMENT CROSS-SLOPES DIFFER FROM THAT SHOWN ON THESE PLANS, RESULTING IN THE DESIGN INTENT REFLECTED ON THESE PLANS NOT BEING ABLE TO BE CONSTRUCTED, THE CONTRACTOR SHALL NOTIFY THE OWNER'S AGENT IMMEDIATELY FOR DIRECTION ON HOW TO PROCEED PRIOR TO COMMENCEMENT OF CONSTRUCTION. THE CONTRACTOR ACCEPTS RESPONSIBILITY FOR ALL COSTS ASSOCIATED WITH CORRECTIVE ACTION IF THESE PROCEDURES ARE NOT FOLLOWED.
- EXISTING UTILITIES SHOWN ON THESE PLANS HAVE BEEN LOCATED ACCORDING TO INFORMATION PROVIDED BY THE AGENCY OPERATING EACH UTILITY. LOCATIONS SHOWN ARE APPROXIMATE ONLY, AND ARE NOT RELIABLE FOR CONSTRUCTION PURPOSES. CALL BLUE STAKE FOR FIELD LOCATION AT (602) 263-1100. THE CONTRACTOR SHALL PROTECT AND MAINTAIN ALL EXISTING UTILITIES ON THE SITE. ANY DAMAGE TO EXISTING UTILITIES, WHETHER SHOWN OR NOT ON THE DRAWING, SHALL BE REPAIRED/REPLACED AT THE CONTRACTOR'S EXPENSE. EXISTING SURFACE FEATURES AND FENCING SHALL BE REPLACED IN LIKE KIND.
- PRIOR TO CONSTRUCTION, THE ENGINEER AND APPLICABLE AGENCY MUST APPROVE ANY ALTERATION, OR VARIANCE FROM THESE PLANS. ANY VARIATIONS FROM THESE PLANS SHALL BE PROPOSED ON CONSTRUCTION FIELD PRINTS AND TRANSMITTED TO THE ENGINEER.
- ANY INSPECTION BY THE CITY, COUNTY, ENGINEER, OR OTHER JURISDICTIONAL AGENCY, SHALL NOT, IN ANY WAY, RELIEVE THE CONTRACTOR FROM ANY OBLIGATION TO PERFORM THE WORK IN STRICT COMPLIANCE WITH APPLICABLE CODES AND AGENCY REQUIREMENTS.
- CONTRACTOR IS RESPONSIBLE FOR PROTECTING ALL STORM DRAIN PIPES, STORM WATER RETENTION PIPES AND DRAINAGE FACILITIES FROM DAMAGE DURING ALL STAGES OF CONSTRUCTION. THE DEPTH OF COVER ON THE STORM DRAIN PIPE IS DESIGNED FOR FINAL GRADE. THEREFORE, EXTRA CARE SUCH AS BERMING OVER PIPES, FLAGGING OR SIGNAGE SHOULD BE USED DURING CONSTRUCTION TO MAINTAIN COVER OR PROTECT THE PIPES.
- THE ENGINEER MAKES NO REPRESENTATION OR GUARANTEE REGARDING EARTHWORK QUANTITIES OR THAT THE EARTHWORK FOR THIS PROJECT WILL BALANCE DUE TO THE VARYING FIELD CONDITIONS, CHANGING SOIL TYPES, ALLOWABLE CONSTRUCTION TOLERANCES AND CONSTRUCTION METHODS THAT ARE BEYOND THE CONTROL OF THE ENGINEER.
- IF PAD CERTIFICATIONS ARE PERFORMED, IT IS UNDERSTOOD THAT THE CERTIFICATION PROVIDES ONLY A REPRESENTATIVE ELEVATION OF THE AVERAGE GRADE OF EACH LOT, BUILDINGS OR UNIT PAD, AND SHALL NOT BE CONSTRUCTED TO INCLUDE YARD AND STREET SUB-GRADE CERTIFICATION OR CERTIFICATION THAT THE ENTIRE PAD IS LEVEL, THAT IT WAS CONSTRUCTED IN THE DESIGNATED LOCATION OR WAS GRADED TO THE CROSS-SECTION SET FORTH ON THE PLANS OR AS DESIGNATED IN THE SOILS REPORT.
- FINISH GRADES SHOWN ON THESE PLANS ARE THE FINAL FINISH GRADES. CONTRACTOR IS RESPONSIBLE FOR OVER-EXCAVATING LANDSCAPE AREAS TO ALLOW FOR PLANTING AND UTILITY TRENCHING SPOILS AND FOR THE FINAL LANDSCAPE TREATMENT (DECOMPOSED GRANITE, LAWN, ETC.).
- UNDERGROUND UTILITIES SHALL BE MARKED IN ACCORDANCE WITH SECTION 40-360 OF THE ARIZONA REVISED STATUTES AND LOCAL MUNICIPALITY REQUIREMENTS.
- SEWER SERVICES SHALL BE INSTALLED TO 5 FEET OF COVER AT 2 FEET BEHIND THE PUE, WHERE POSSIBLE.
- CURB RAMPS ON ACCESSIBLE ROUTES SHALL COMPLY WITH ADA 406, 405.2 THROUGH 405.5 AND 405.10, ADA 406.1.
- THE RUNNING SLOPE OF WALKING SURFACES SHALL NOT BE STEEPER THAN 1:20. THE CROSS SLOPE OF WALKING SURFACES SHALL NOT BE STEEPER THAN 1:48, 2010 ADA 403.3.
- INDIVIDUAL WATER SERVICE CONNECTIONS WHERE PRESSURES EXCEED 80 PSI WILL REQUIRE INDIVIDUAL PRESSURE REDUCING VALVES (PRV'S).

Copyright HilgartWilson - This plan document set is the sole property of HilgartWilson. No alterations to these plans, other than adding "as-built" information, are allowed by anyone other than authorized HilgartWilson employees.

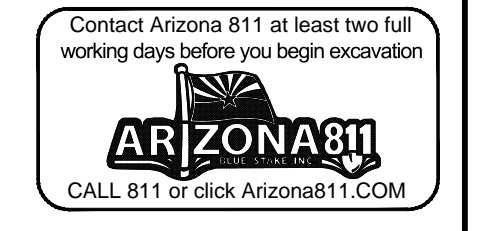

PLAN NAME FLOREO AT TERAVALIS PARCEL 48 NOTES & DETAILS	
ENGINEER INFORMATION 	
COB PERMITTING APPROVED SEAL	COB ENGINEERING APPROVED SEAL
AS-BUILT SEAL	DESIGN SEAL
ORIGINAL PLAN DATE NOV 2022	LATEST REVISION DATE
PROJECT NUMBER 1175	SHEET NUMBER SHT. DT02 3 OF 8

Copyright Hilgartwilson - This plan document set is the sole property of Hilgartwilson. No attachments to these plans, other than adding "as-built" information, are allowed by anyone other than authorized Hilgartwilson employees.

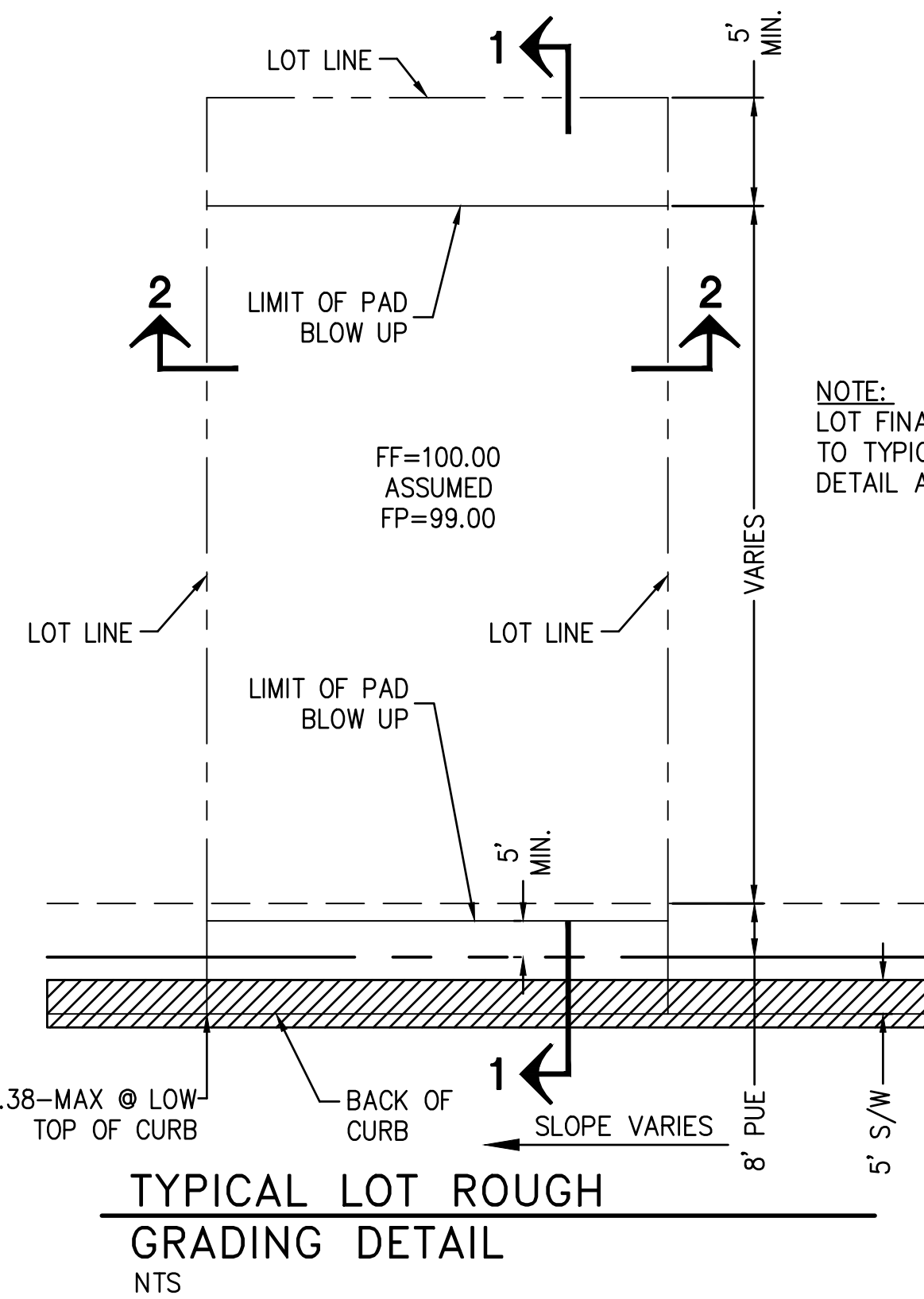

1-1 TYPICAL ROUGH GRADING SECTION THRU LOT NTS

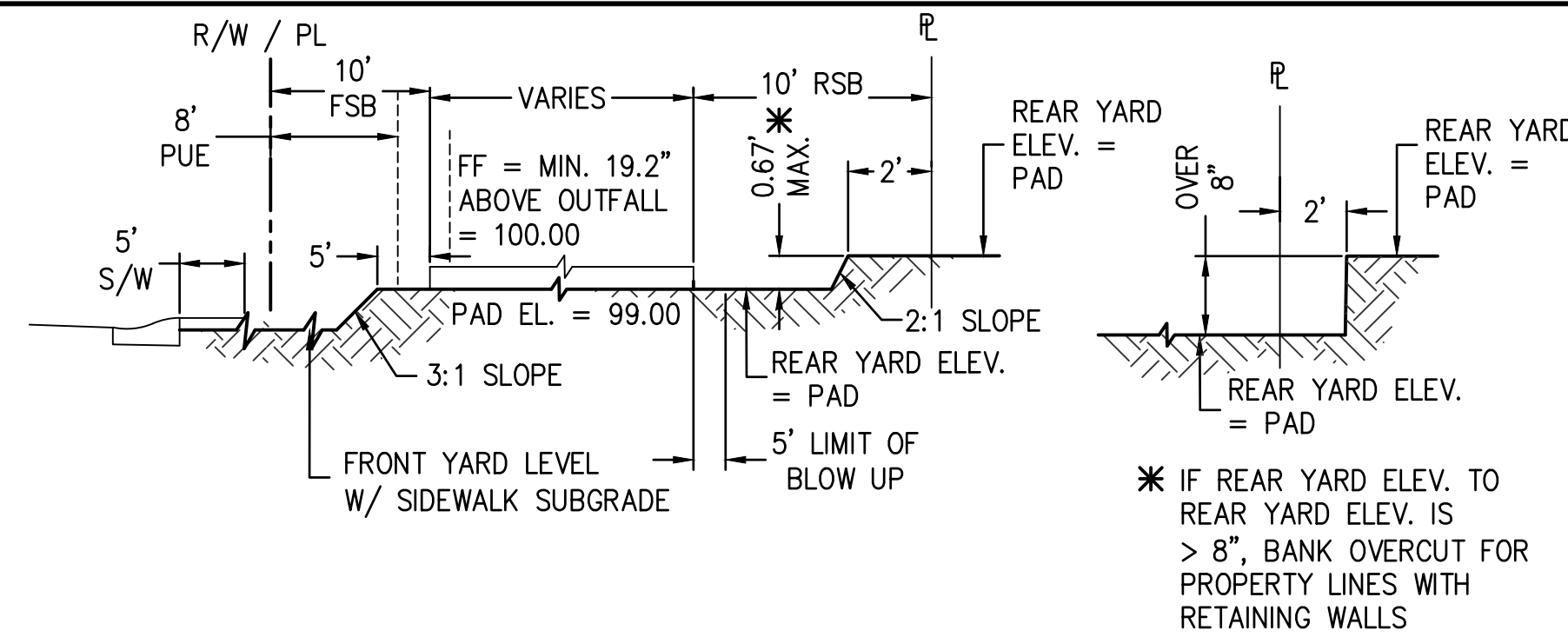

2-2 TYPICAL ROUGH GRADING SIDE YARD TO SIDE YARD NTS

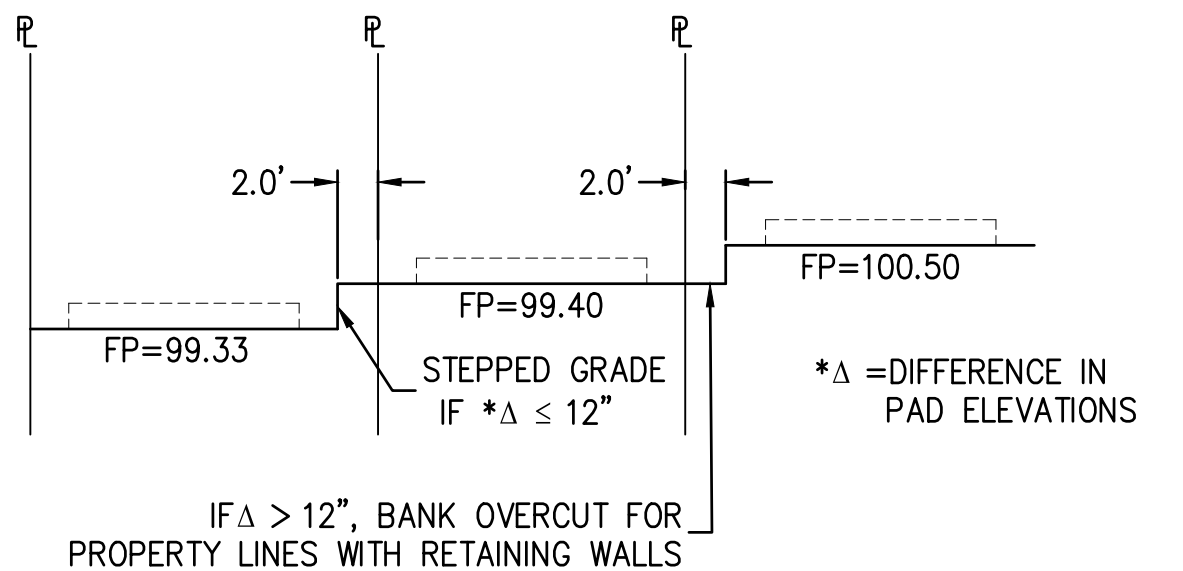

NOTE:
LOT FINAL GRADING TO CONFORM TO TYPICAL FINISHED LOT GRADING DETAIL AND PARCEL GRADING PLANS

* IF REAR YARD ELEV. TO REAR YARD ELEV. IS > 8", BANK OVERCUT FOR PROPERTY LINES WITH RETAINING WALLS

*Δ = DIFFERENCE IN PAD ELEVATIONS

IF Δ > 12", BANK OVERCUT FOR PROPERTY LINES WITH RETAINING WALLS

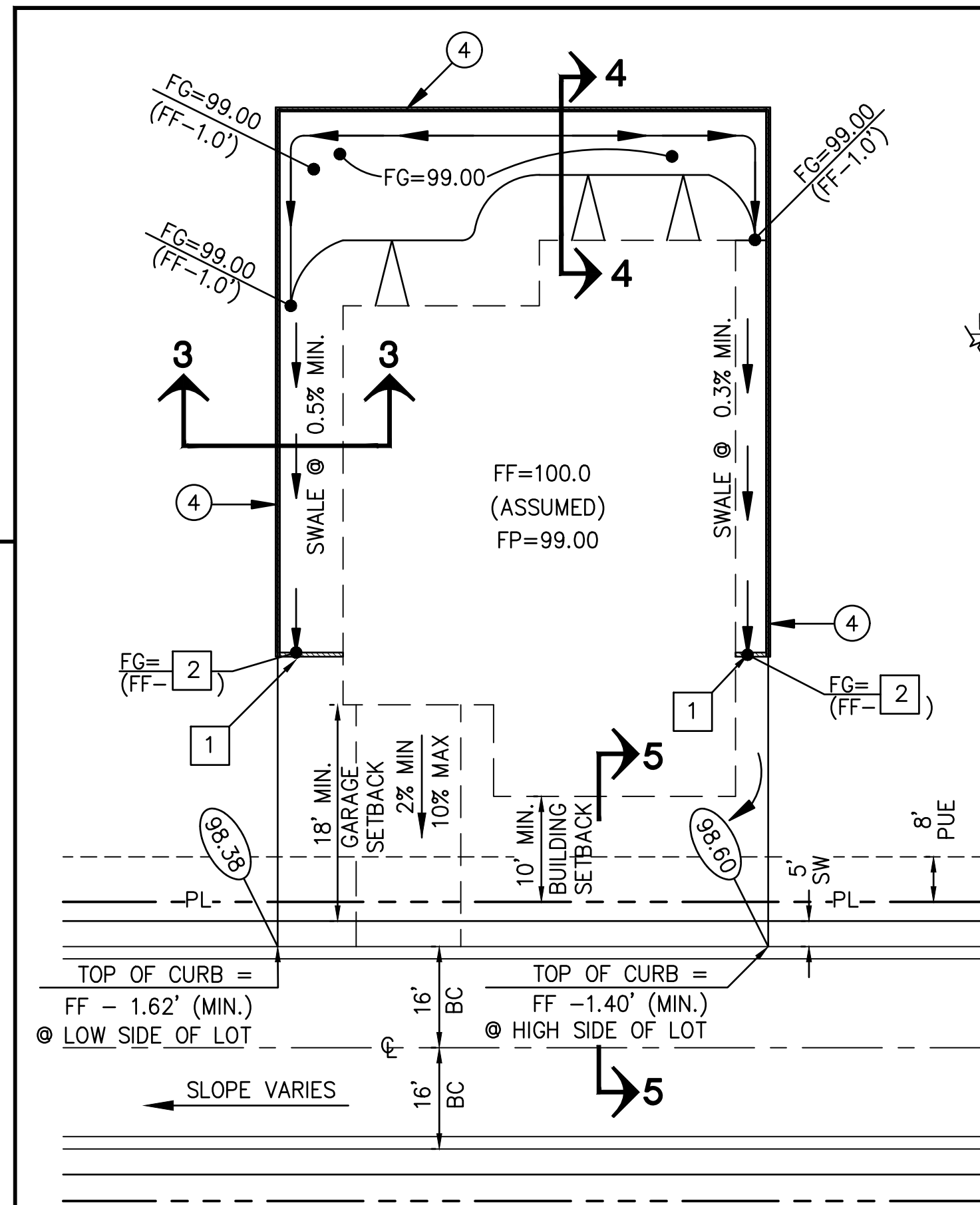

3-3 TYPICAL FINISHED SIDE YARD NTS

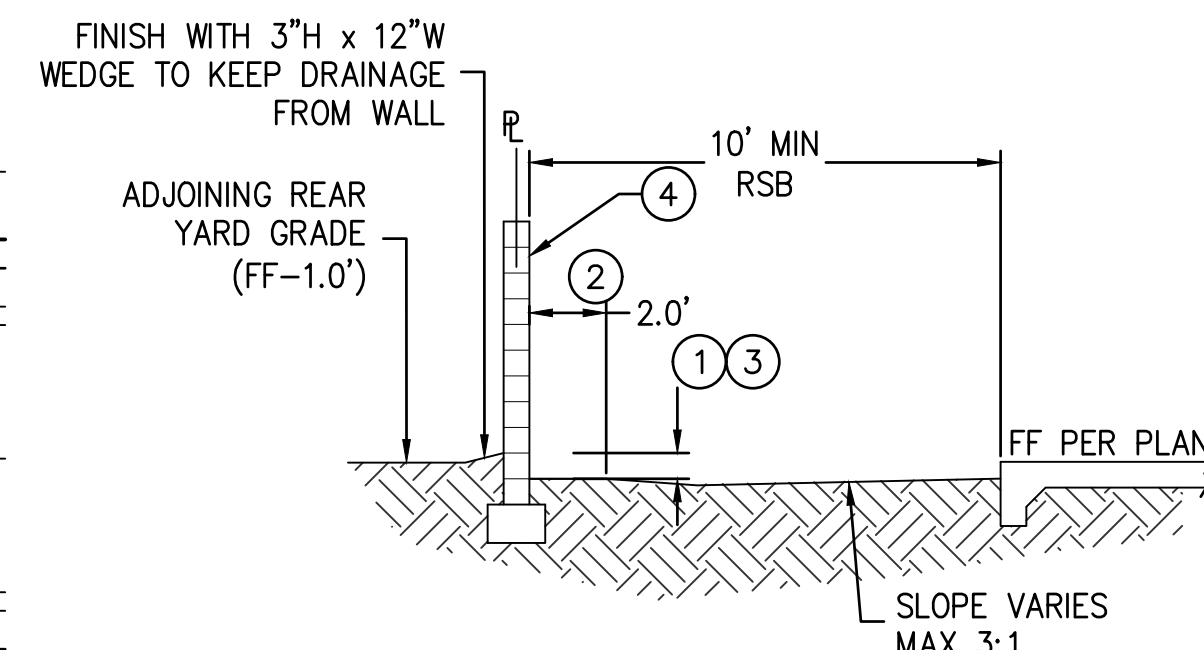

4-4 TYPICAL FINISHED REAR YARD NTS

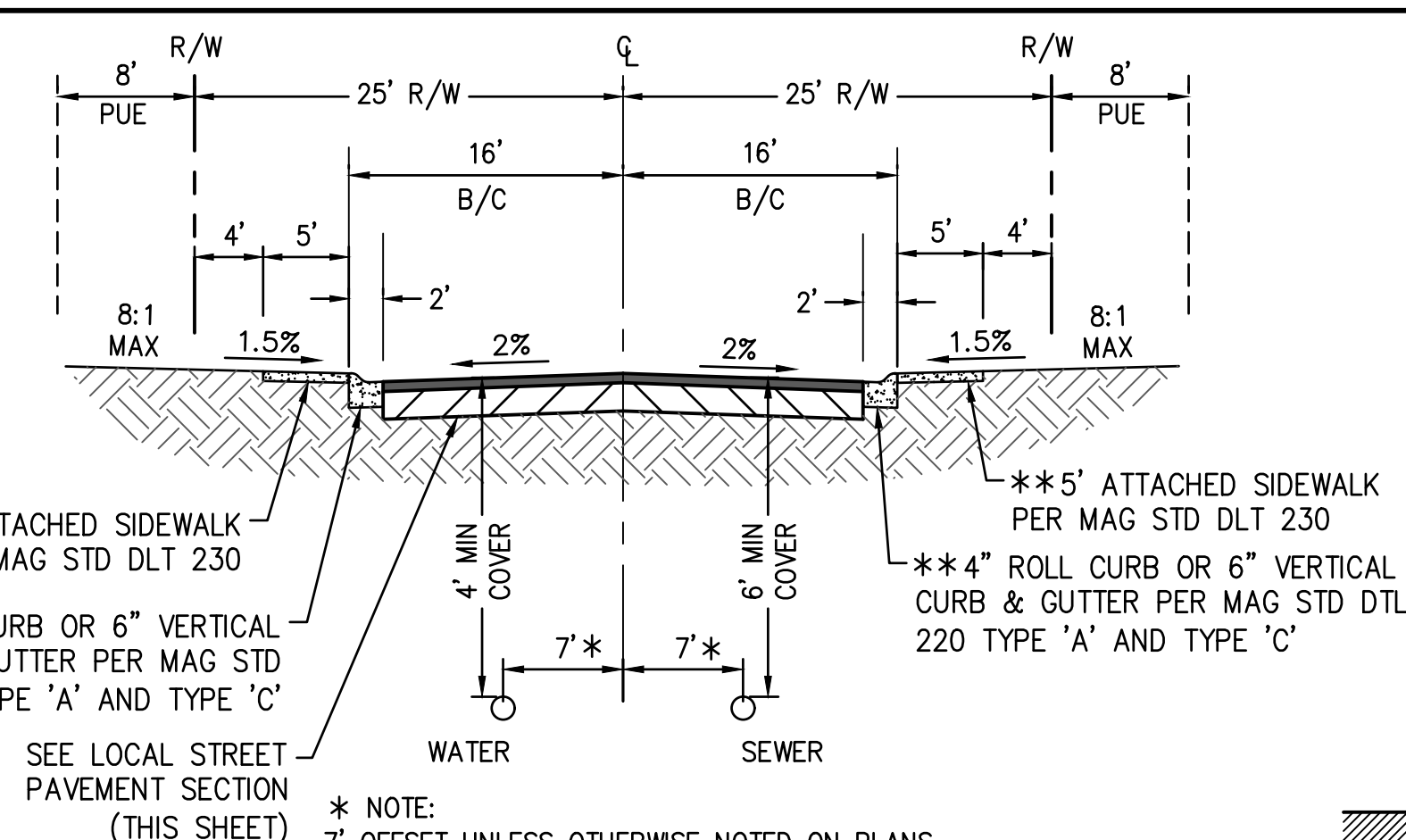

TYPICAL LOCAL STREET NTS

** IF CONTRACTOR DECIDES TO POUR CURB, GUTTER AND SIDEWALK MONOLITHICALLY THEN COB STD DTL 63225 SHALL BE USED AND 5" THICK SIDEWALK WILL NO LONGER BE REQUIRED.

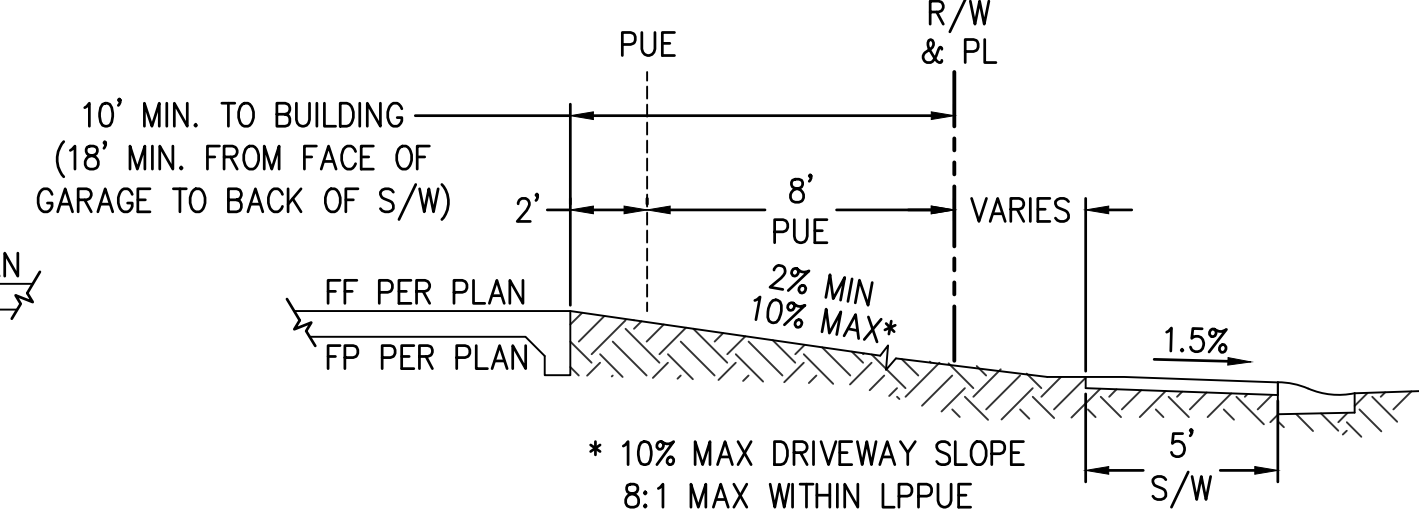

5-5 TYPICAL FINISH GRADING SECTION THRU FRONT YARD NTS

RETAINING WALL TABLE

HEIGHT	QUANTITY
1'-4"	367 LF
2'-0"	695 LF
2'-8"	1351 LF
3'-4"	532 LF
4'-0"	240 LF
4'-8"	322 LF
TOTAL	3507 LF

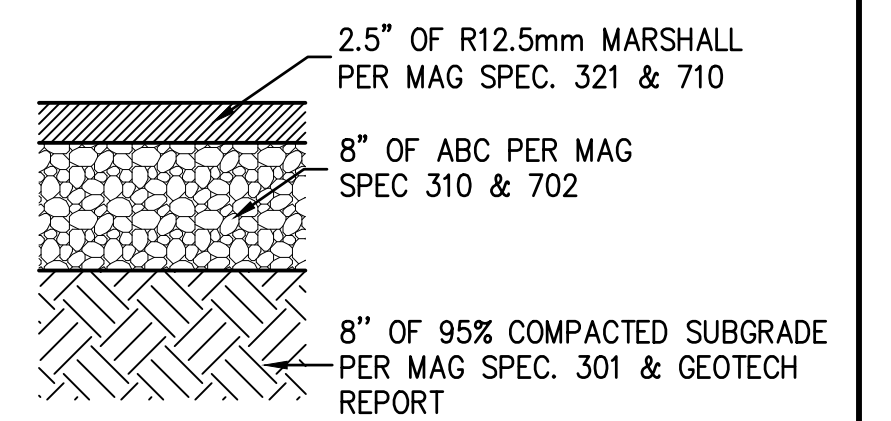

LOCAL STREET PAVEMENT SECTION

(PER COB STD DTL 63170) NTS



WALL & RETAINING WALL CRITERIA:

- AS IDENTIFIED ON THE PLANS, PROPOSED RETAINING WALLS ARE SHOWN UNDER THE FOLLOWING CONDITIONS:
- SIDE YARD TO SIDE YARD GRADE DIFFERENTIALS GREATER THAN 12".
 - REAR YARD TO REAR YARD GRADE DIFFERENTIALS GREATER THAN 8".
 - HIGH SIDE YARD TO LOW REAR YARD GRADE DIFFERENTIALS GREATER THAN 8".
 - HIGH REAR YARD TO LOW SIDE YARD GRADE DIFFERENTIALS GREATER THAN 12".

IN ALL OTHER CONDITIONS, HOMEOWNER/DEVELOPER SHALL DETERMINE TYPE AND SIZE OF WALL. THE DESIGN OF WALLS INCLUDING MASONRY BLOCK AND RETAINING WALLS SHALL BE BY HOMEOWNER'S/DEVELOPER'S STRUCTURAL ENGINEER. WALL HEIGHTS AND GRADE DIFFERENTIAL ACROSS WALLS SHALL BE DETERMINED AND APPROVED BY HOMEOWNER'S/DEVELOPER'S STRUCTURAL ENGINEER.

WALL & RETAINING WALL NOTES:

- NOTHING ON THE PLANS SHALL BE INTERPRETED OR CONSTRUED TO DETERMINE THE ALLOWABLE DROP ACROSS WALLS. ANY ELEVATION DROPS SHALL BE IN ACCORDANCE WITH THE STRUCTURAL DETAILS & SPECIFICATIONS BY OTHERS.
- 2.0' MIN SHELF REQUIRED.
- REFER TO RETAINING WALL STRUCTURAL DETAILS & SPECIFICATIONS BY OTHERS. SEE STRUCTURAL PLAN.
- REFER TO SITE PLAN WALL PLAN FOR WALL TYPES AND DETAILS.
- INSTALL WALL OPENING W/ BOTTOM OF OPENING AT ELEVATION AS NOTED. OPENING TO HAVE 32 SQ. IN. MIN. CROSS SECTIONAL AREA. CONTRACTOR TO VERIFY THAT WALL OPENING MEETS MIN. CROSS SECTIONAL AREA.
- LOCATION AND ELEVATION TO BE DETERMINED BY HOMEOWNER/DEVELOPER HOLDING THE MIN. 0.5% SWALE FOR LOW SIDE AND 0.3% FOR HIGH SIDE FROM THE REAR YARD.

TYPICAL FINISHED LOT GRADING DETAIL NTS

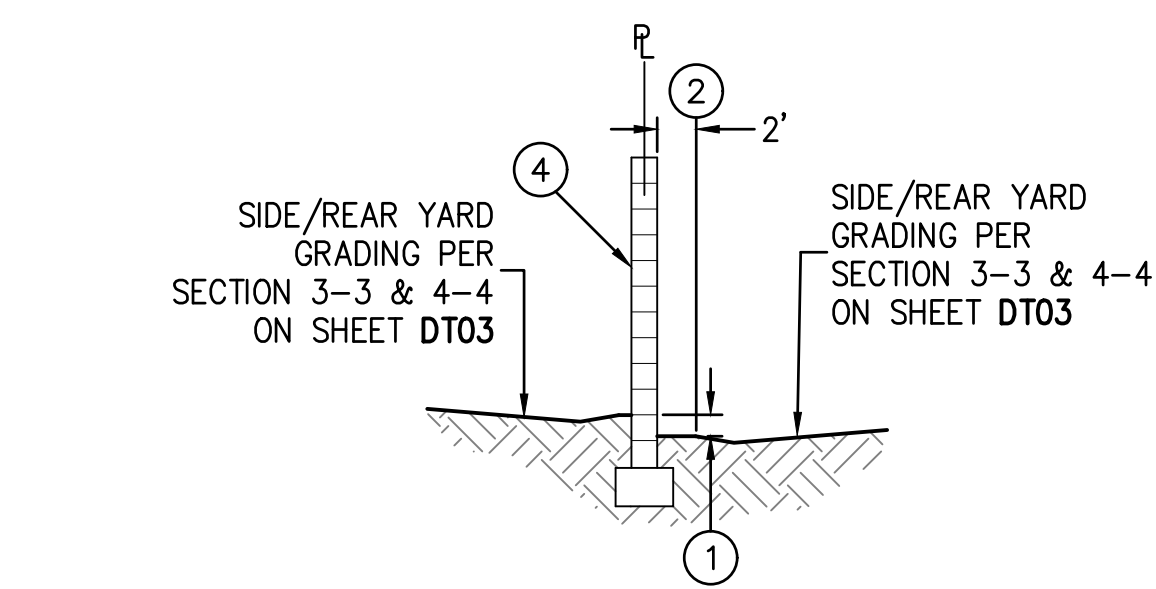

A WALL SECTION SIDE/REAR YARD TO SIDE/REAR YARD NTS

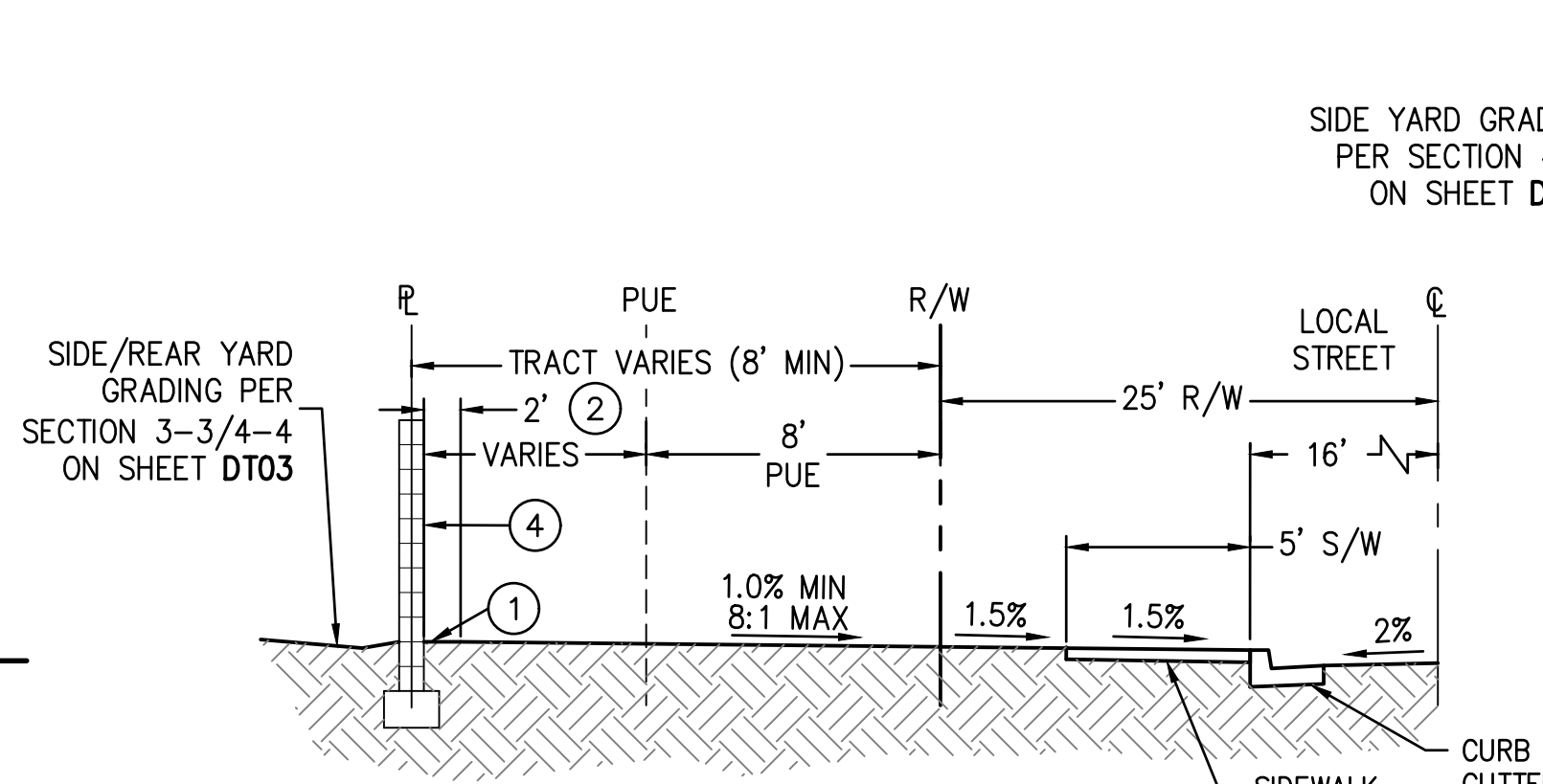

C WALL SECTION SIDE/REAR YARD TO STREET NTS

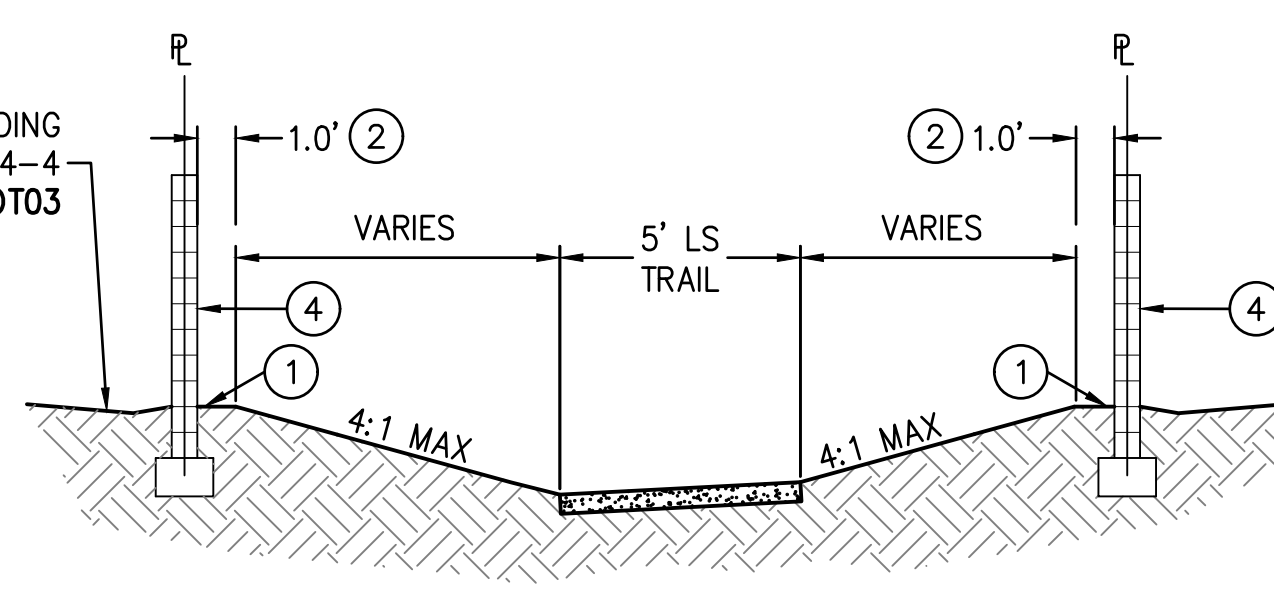

O WALL SECTION SIDE/REAR YARD TO SWALE N.T.S.

PLAN NAME
**FLOREO AT TERAVALIS
PARCEL 48
NOTES & DETAILS**

ENGINEER INFORMATION	
HILGARTWILSON	
COB PERMITTING APPROVED SEAL	COB ENGINEERING APPROVED SEAL
AS-BUILT SEAL	DESIGN SEAL
ORIGINAL PLAN DATE NOV 2022	LATEST REVISION DATE
PROJECT NUMBER 1175	SHEET NUMBER SHT. DT03 4 OF 8

Copyright: Hilgartwilson - This plan document set is the sole property of Hilgartwilson. No alterations to these plans, other than adding "as-built" information, are allowed by anyone other than authorized Hilgartwilson employees.

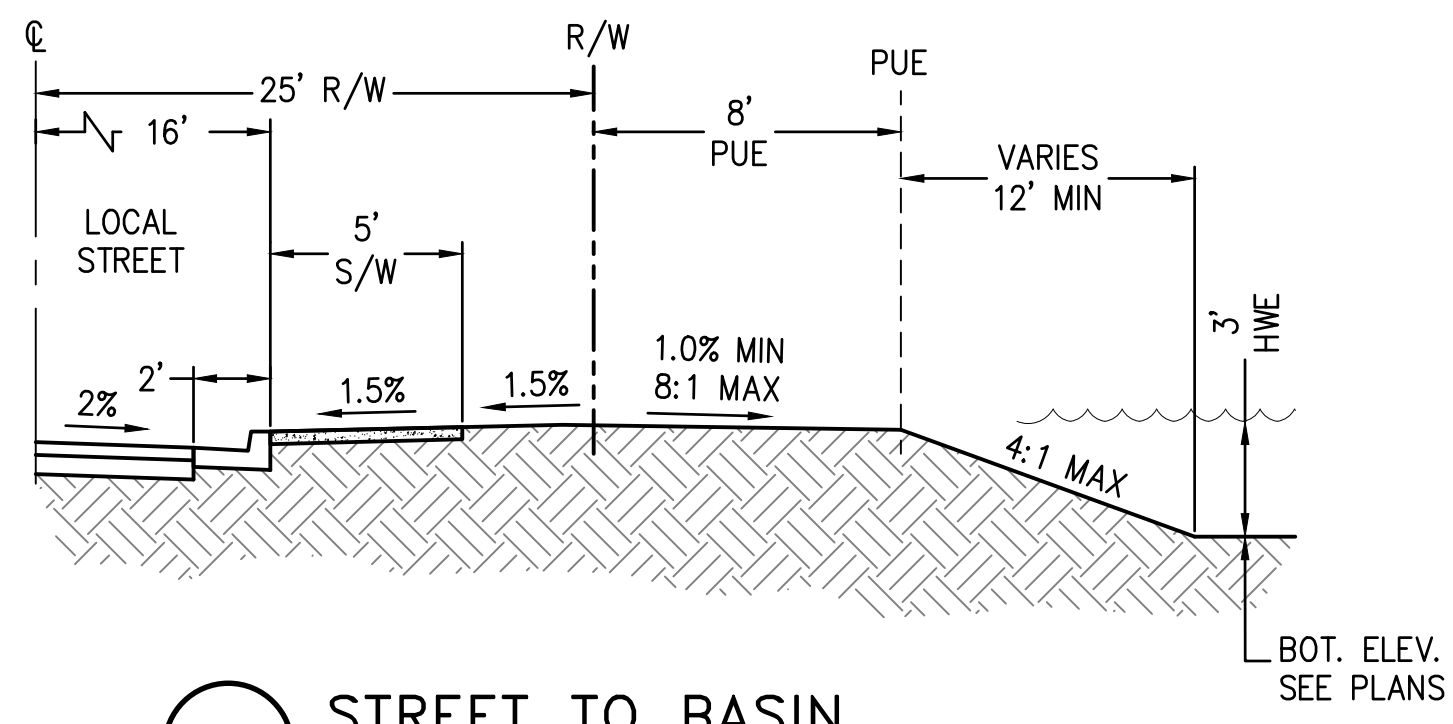

E STREET TO BASIN
N.T.S.

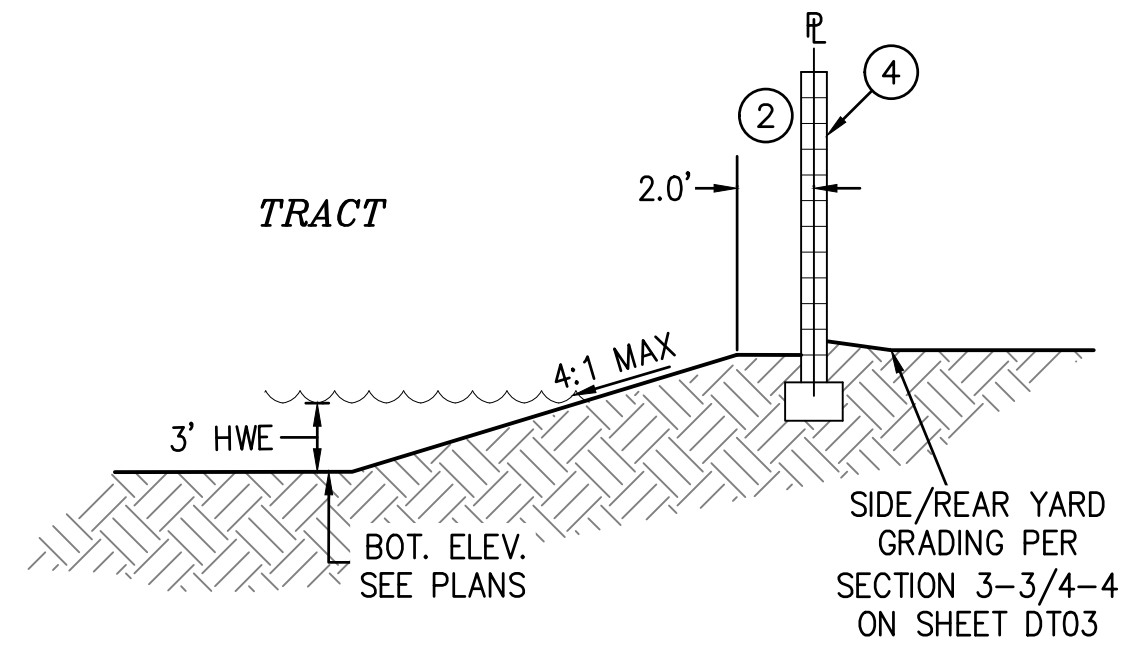

G WALL SECTION
SIDE/REAR YARD TO BASIN
N.T.S.

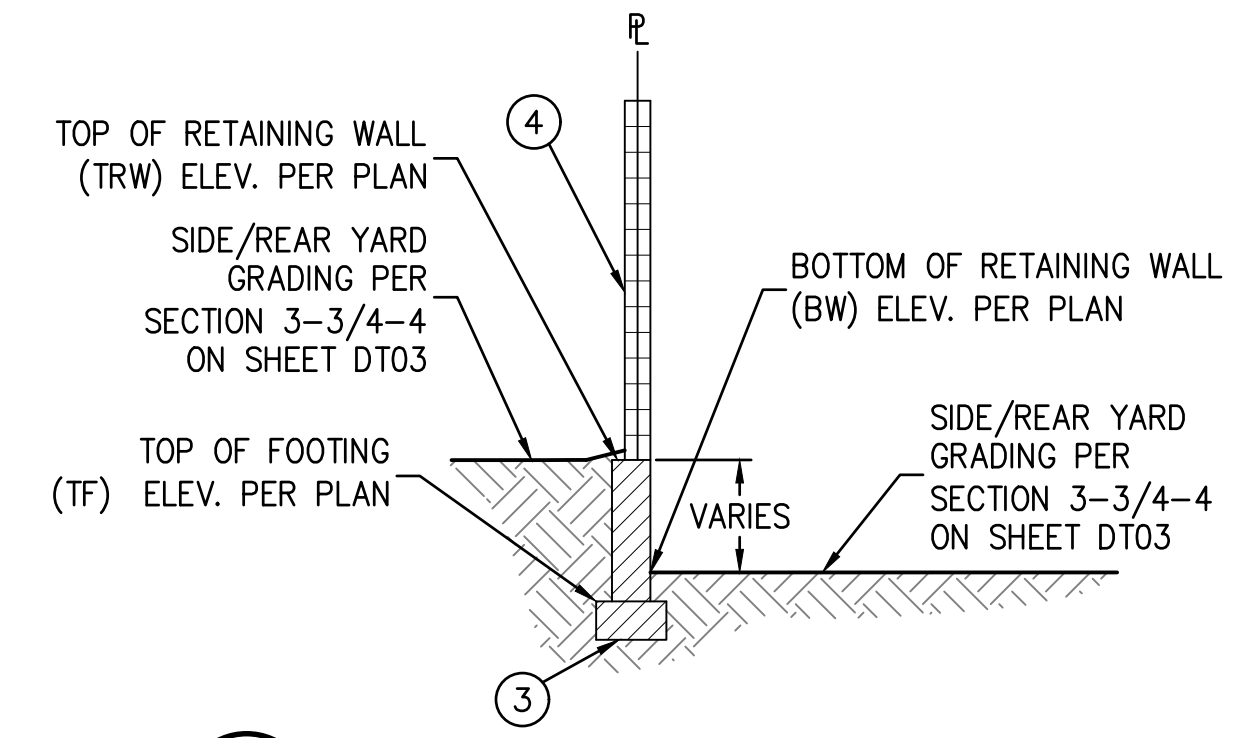

H RETAINING WALL SECTION
SIDE/REAR YARD TO SIDE YARD/
REAR YARD
N.T.S.

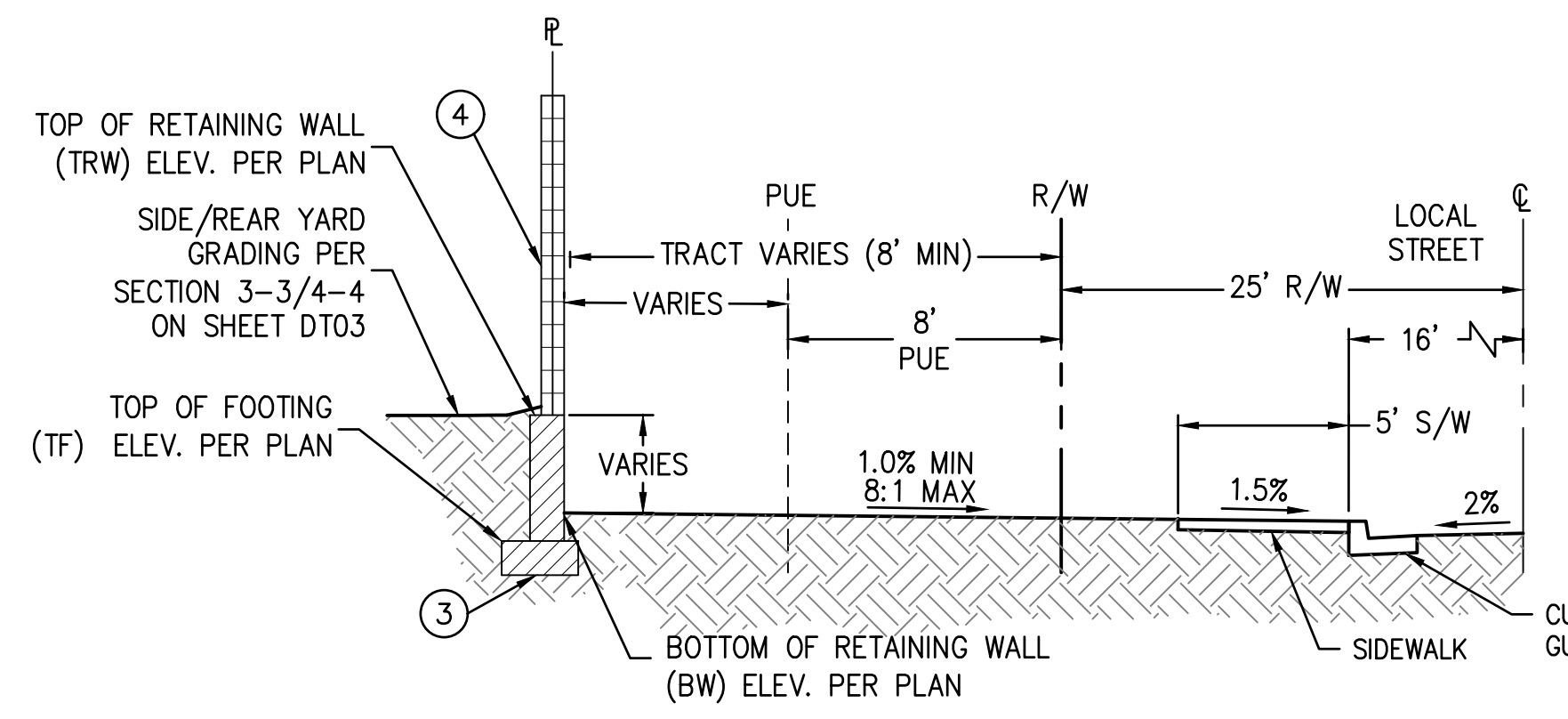

J RETAINING WALL SECTION
SIDE/REAR YARD TO STREET
N.T.S.

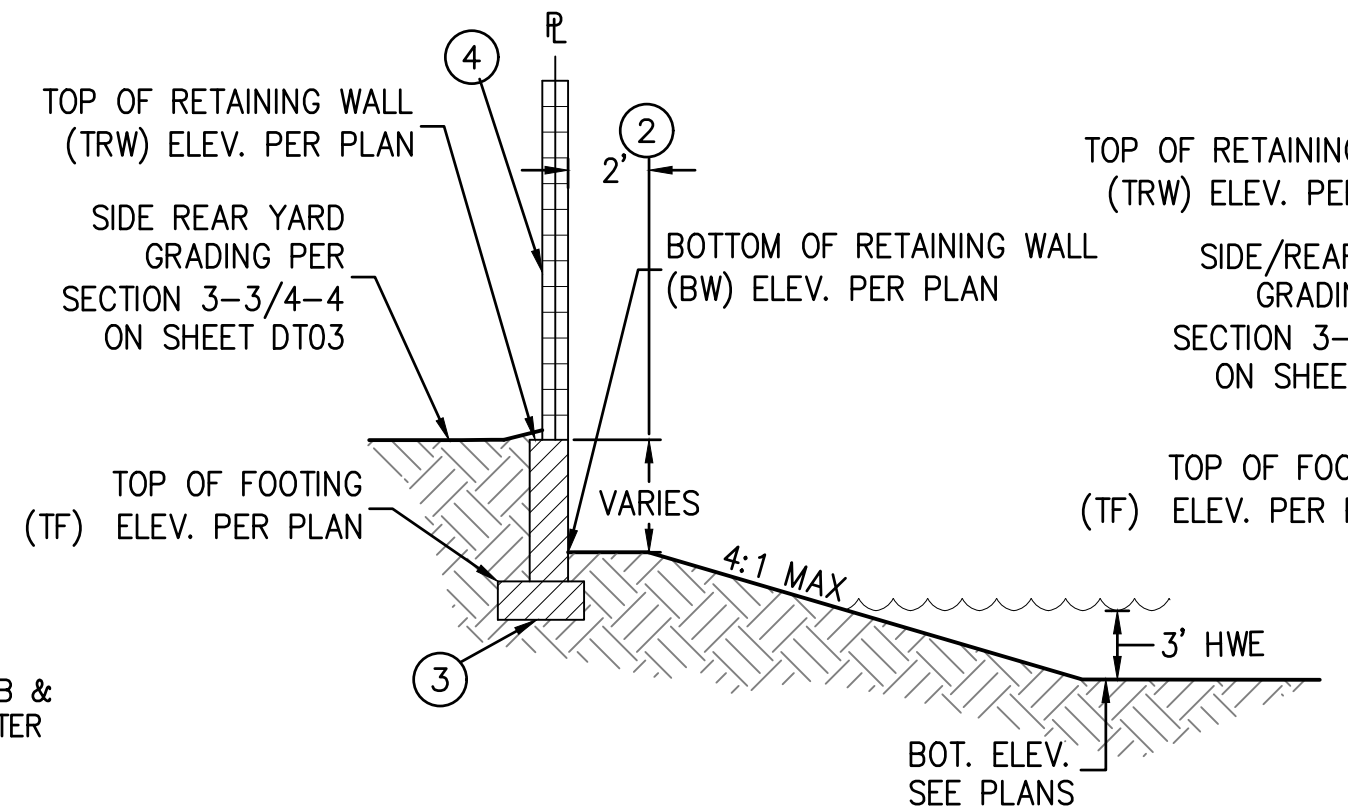

K RETAINING WALL SECTION
SIDE/REAR YARD TO BASIN
N.T.S.

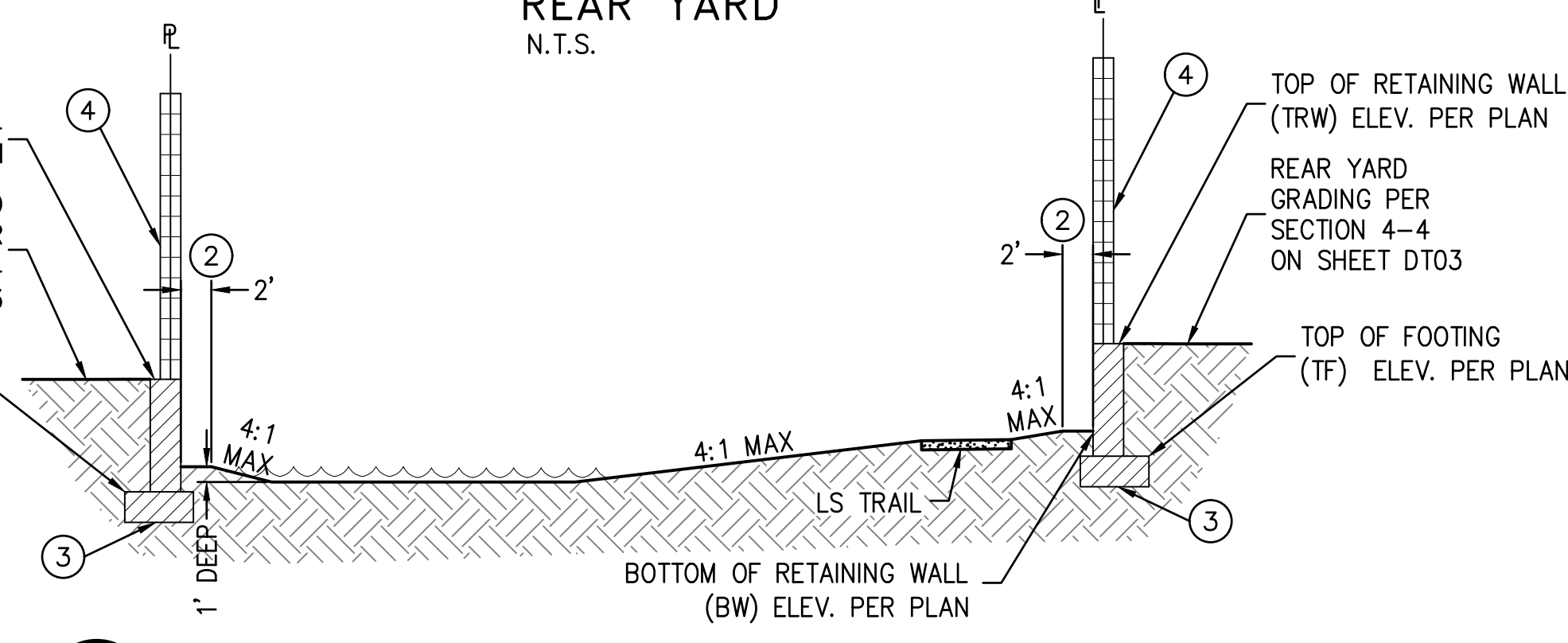

R RETAINING WALL SECTION
SIDE/REAR YARD TO BASIN TO REAR YARD
N.T.S.

WALL & RETAINING WALL CRITERIA:
AS IDENTIFIED ON THE PLANS, PROPOSED RETAINING WALLS ARE SHOWN UNDER THE FOLLOWING CONDITIONS:

- A) SIDE YARD TO SIDE YARD GRADE DIFFERENTIALS GREATER THAN 12".
- B) REAR YARD TO REAR YARD GRADE DIFFERENTIALS GREATER THAN 8".
- C) HIGH SIDE YARD TO LOW REAR YARD GRADE DIFFERENTIALS GREATER THAN 8".
- D) HIGH REAR YARD TO LOW SIDE YARD GRADE DIFFERENTIALS GREATER THAN 12".

IN ALL OTHER CONDITIONS, HOMEBUILDER/DEVELOPER SHALL DETERMINE TYPE AND SIZE OF WALL. THE DESIGN OF WALLS INCLUDING MASONRY BLOCK AND RETAINING WALLS SHALL BE BY HOMEBUILDER'S/DEVELOPER'S STRUCTURAL ENGINEER. WALL HEIGHTS AND GRADE DIFFERENTIAL ACROSS WALLS SHALL BE DETERMINED AND APPROVED BY HOMEBUILDER'S/DEVELOPER'S STRUCTURAL ENGINEER.

WALL & RETAINING WALL NOTES:

- 1) NOTHING ON THE PLANS SHALL BE INTERPRETED OR CONSTRUED TO DETERMINE THE ALLOWABLE DROP ACROSS WALLS. ANY ELEVATION DROPS SHALL BE IN ACCORDANCE WITH THE STRUCTURAL DETAILS & SPECIFICATIONS BY OTHERS.
- 2) 2.0' MIN SHELF REQUIRED.
- 3) REFER TO RETAINING WALL STRUCTURAL DETAILS & SPECIFICATIONS BY OTHERS. SEE STRUCTURAL PLAN.
- 4) REFER TO SITE PLAN WALL PLAN FOR WALL TYPES AND DETAILS.

1) INSTALL WALL OPENING W/ BOTTOM OF OPENING AT ELEVATION AS NOTED. OPENING TO HAVE 32 SQ. IN. MIN. CROSS SECTIONAL AREA. CONTRACTOR TO VERIFY THAT WALL OPENING MEETS MIN. CROSS SECTIONAL AREA.

2) LOCATION AND ELEVATION TO BE DETERMINED BY HOMEBUILDER/DEVELOPER HOLDING THE MIN. 0.5% SWALE FOR LOW SIDE AND 0.3% FOR HIGH SIDE FROM THE REAR YARD.

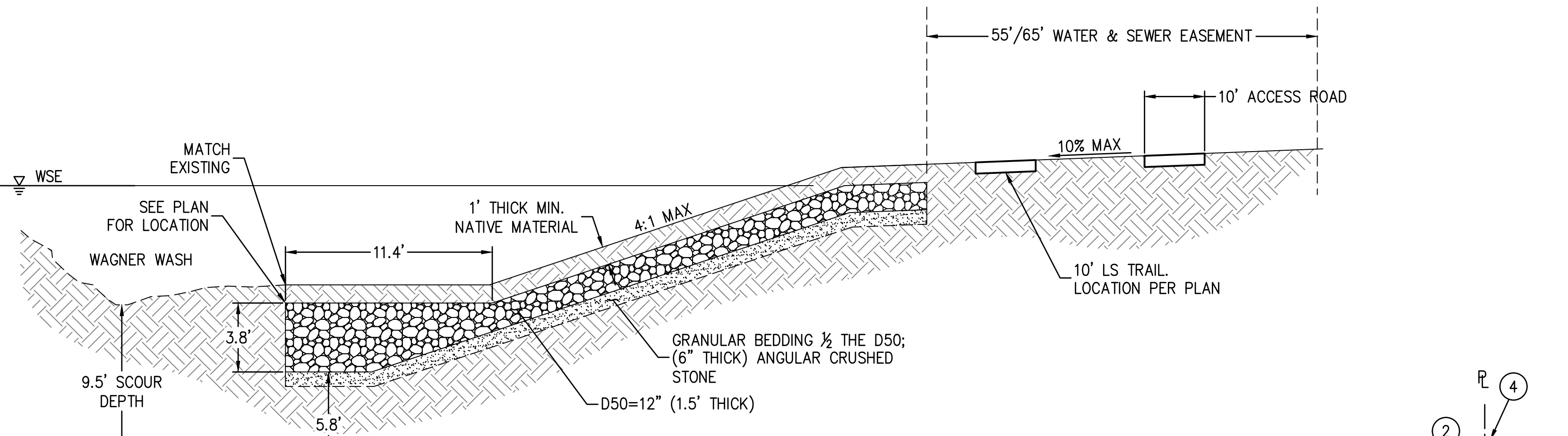

Q LAUNCHABLE RIP-RAP SECTION
EASEMENT TO WAGNER WASH
SCALE = N.T.S.

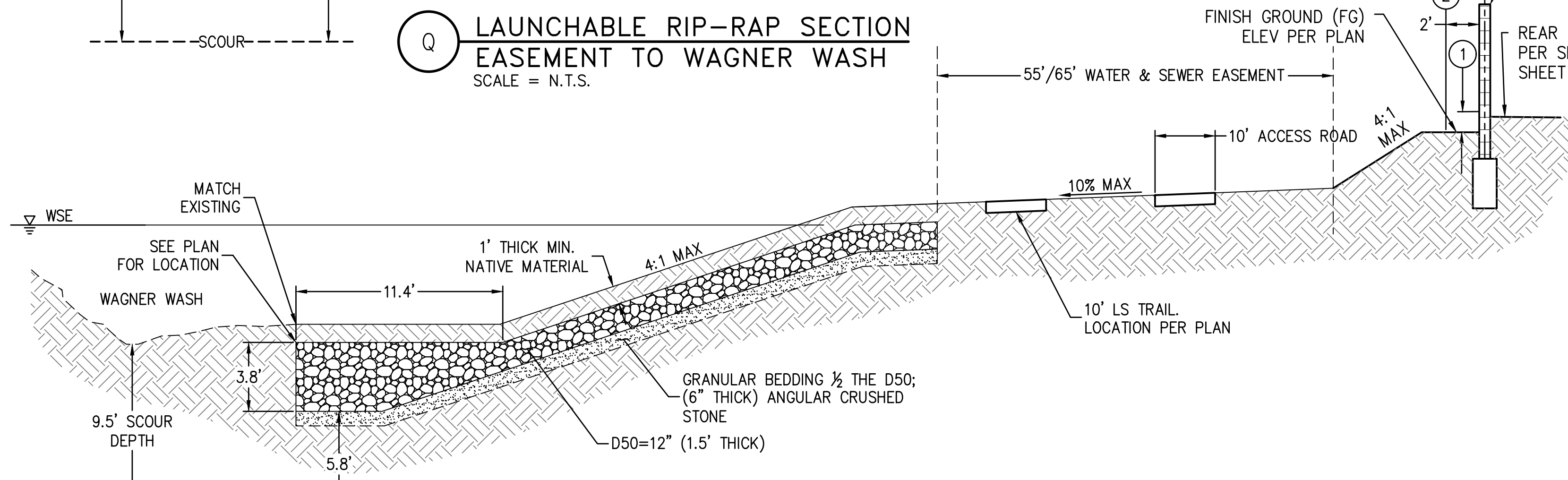

S LAUNCHABLE RIP-RAP SECTION
EASEMENT TO WAGNER WASH P48
SCALE = N.T.S.

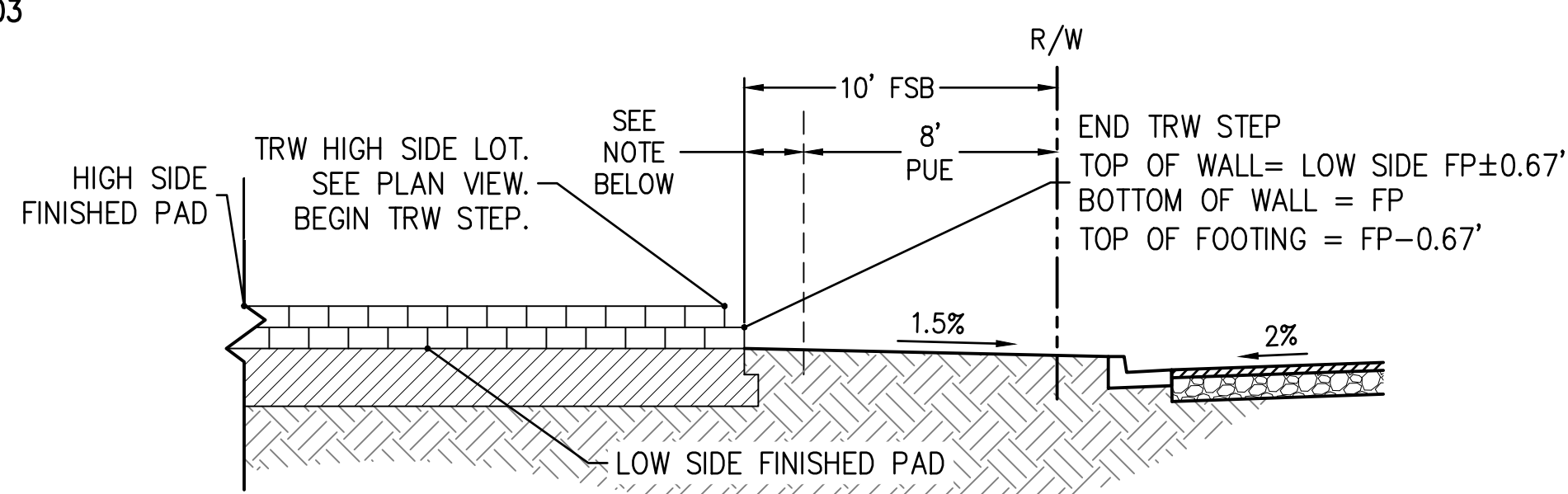

NOTES:

1. CONTRACTOR SHALL BEGIN STEPPING RETAINING WALL 2' BACK OF FRONT SET BACK. STEPS SHALL BE IN TYPICAL CMU BLOCK INTERVALS TO MATCH SLOPE FROM BLOW UP LIMIT TO BACK OF PUE.
2. RETAINING WALLS, LOCATED WITHIN THE REQUIRED FRONT YARD SET BACK, SHALL NOT EXCEED A HEIGHT OF ONE (1) FEET AS MEASURED FROM FINISHED GRADE.

RETAINING WALL STEP DETAIL
N.T.S.



<p>PLAN NAME FLOREO AT TERAVALIS PARCEL 48 NOTES & DETAILS</p>	
<p>ENGINEER INFORMATION HILGARTWILSON</p>	
<p>COB PERMITTING APPROVED SEAL</p>	<p>COB ENGINEERING APPROVED SEAL</p>
<p>AS-BUILT SEAL</p>	<p>DESIGN SEAL <i>[Signature]</i> 23227 DAVID W. GEORGE REGISTERED PROFESSIONAL ENGINEER EXPIRES 12/31/23</p>
<p>ORIGINAL PLAN DATE NOV 2022</p>	<p>LATEST REVISION DATE</p>
<p>PROJECT NUMBER 1175</p>	<p>SHEET NUMBER SHT. DT04 5 OF 8</p>
<p>COB PLAN TRACKING # ENG-21-0595</p>	<p>COB PERMIT #</p>

Copyright, Hilgartwilson - This plan document set is the sole property of Hilgartwilson. No attachments to these plans, other than adding "as-built" information, are allowed by anyone other than authorized Hilgartwilson employees.

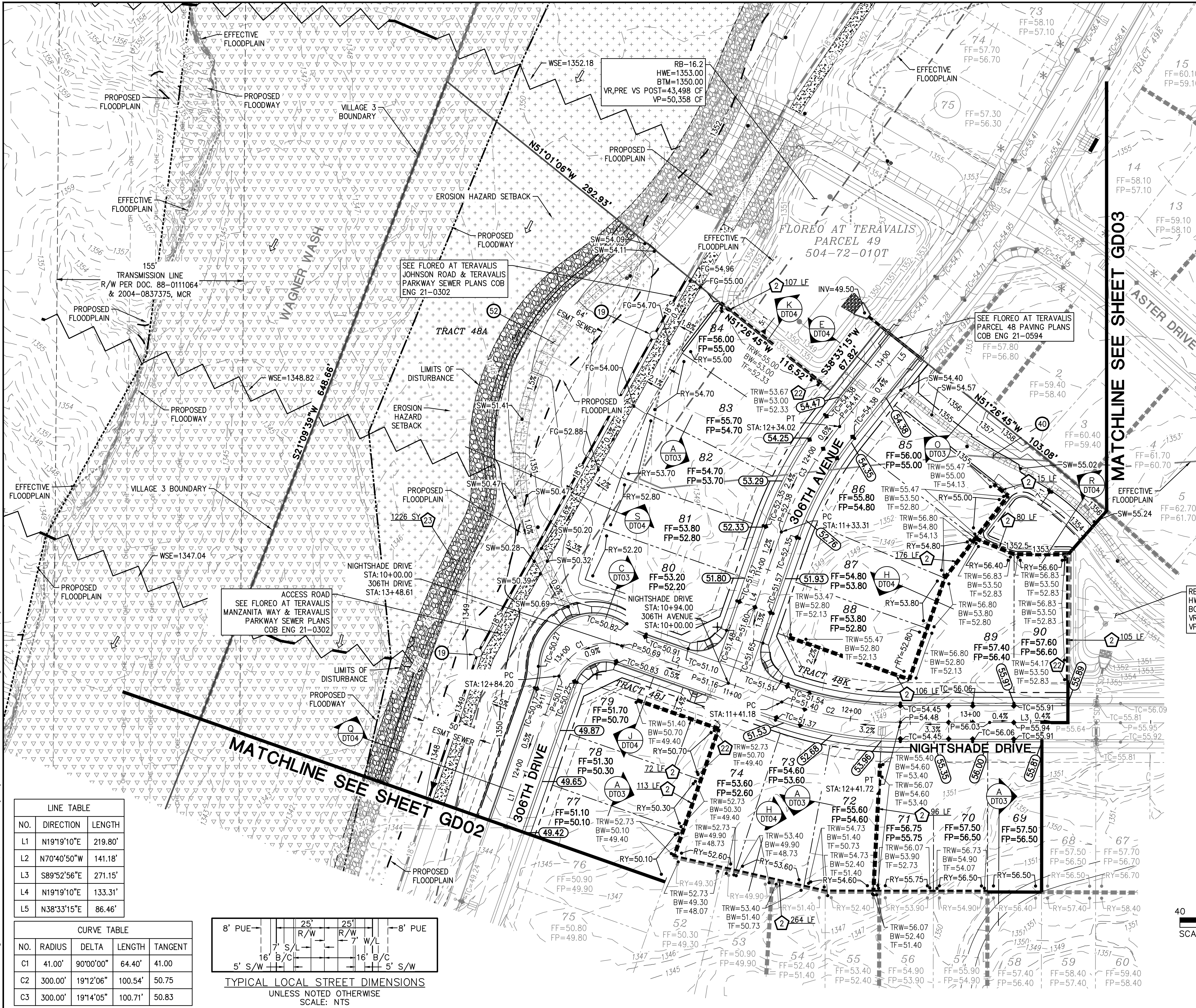

- PAVING CONSTRUCTION NOTES**
- 19 ADJUST MANHOLE FRAME & COVER PER MAG STD 2 EA DTL 422 AND COB DTL 41260.
 - 40 CONSTRUCT 5' PRIVATE LANDSCAPE SIDEWALK 990 SF PER MAG STD DTL 230.
 - 52 CONSTRUCT 10' PRIVATE LANDSCAPE SIDEWALK 3484 SF PER MAG STD DTL 230.
- GRADING CONSTRUCTION NOTES**
- 2 CONSTRUCT RETAINING WALL, ELEVATION SHOWN ON PLANS. REFER TO STRUCTURAL PLAN BY OTHERS. 1134 LF
 - 22 STEP RETAINING WALL PER RETAINING WALL STEP 3 EA DETAIL SHEET DT04.
 - 23 PLACE LOOSE ANGULAR LAUNCHABLE RIP-RAP PER MAG SPEC SECTION 220; D50=12" ON 6" THICK GRANULAR, ANGULAR, CRUSHED STONE BEDDING. SEE DETAIL Q ON DT04. 1226 SY

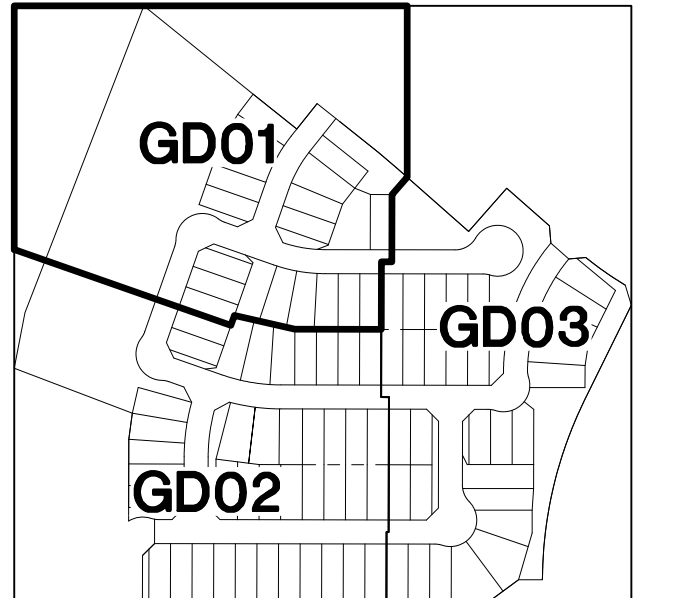

LINE TABLE

NO.	DIRECTION	LENGTH
L1	N19°19'10"E	219.80'
L2	N70°40'50"W	141.18'
L3	S89°52'56"E	271.15'
L4	N19°19'10"E	133.31'
L5	N38°33'15"E	86.46'

CURVE TABLE

NO.	RADIUS	DELTA	LENGTH	TANGENT
C1	41.00'	90°00'00"	64.40'	41.00
C2	300.00'	19°12'06"	100.54'	50.75
C3	300.00'	19°14'05"	100.71'	50.83

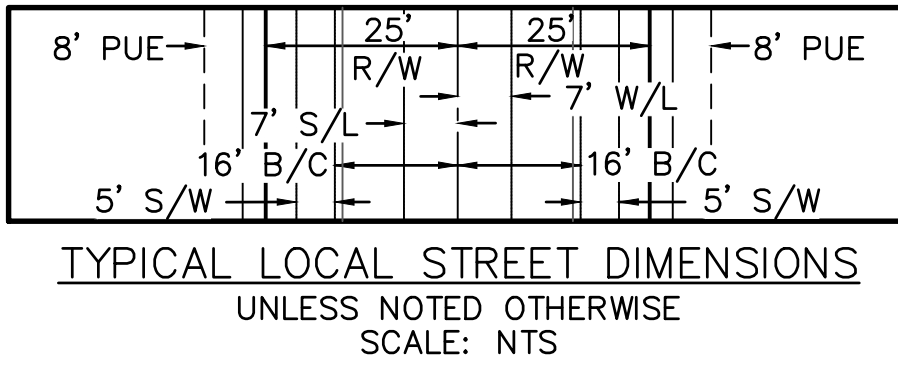

PLAN NAME
**FLOREO AT TERAVALIS
PARCEL 48
GRADING PLAN**

ENGINEER INFORMATION
HILGARTWILSON

COB PERMITTING APPROVED SEAL
COB ENGINEERING APPROVED SEAL

AS-BUILT SEAL
DESIGN SEAL
[Signature]
23227
DAN W. GEORGE
REGISTERED PROFESSIONAL ENGINEER
EXPIRES 12/31/23

ORIGINAL PLAN DATE: NOV 2022
LATEST REVISION DATE:

PROJECT NUMBER: 1175
SHEET NUMBER: **GD01** OF 8

COB PLAN TRACKING # ENG-21-0595
COB PERMIT #

Copyright, Hilgartwilson - This plan document set is the sole property of Hilgartwilson. No attachments to these plans, other than adding "as-built" information, are allowed by anyone other than authorized Hilgartwilson employees.

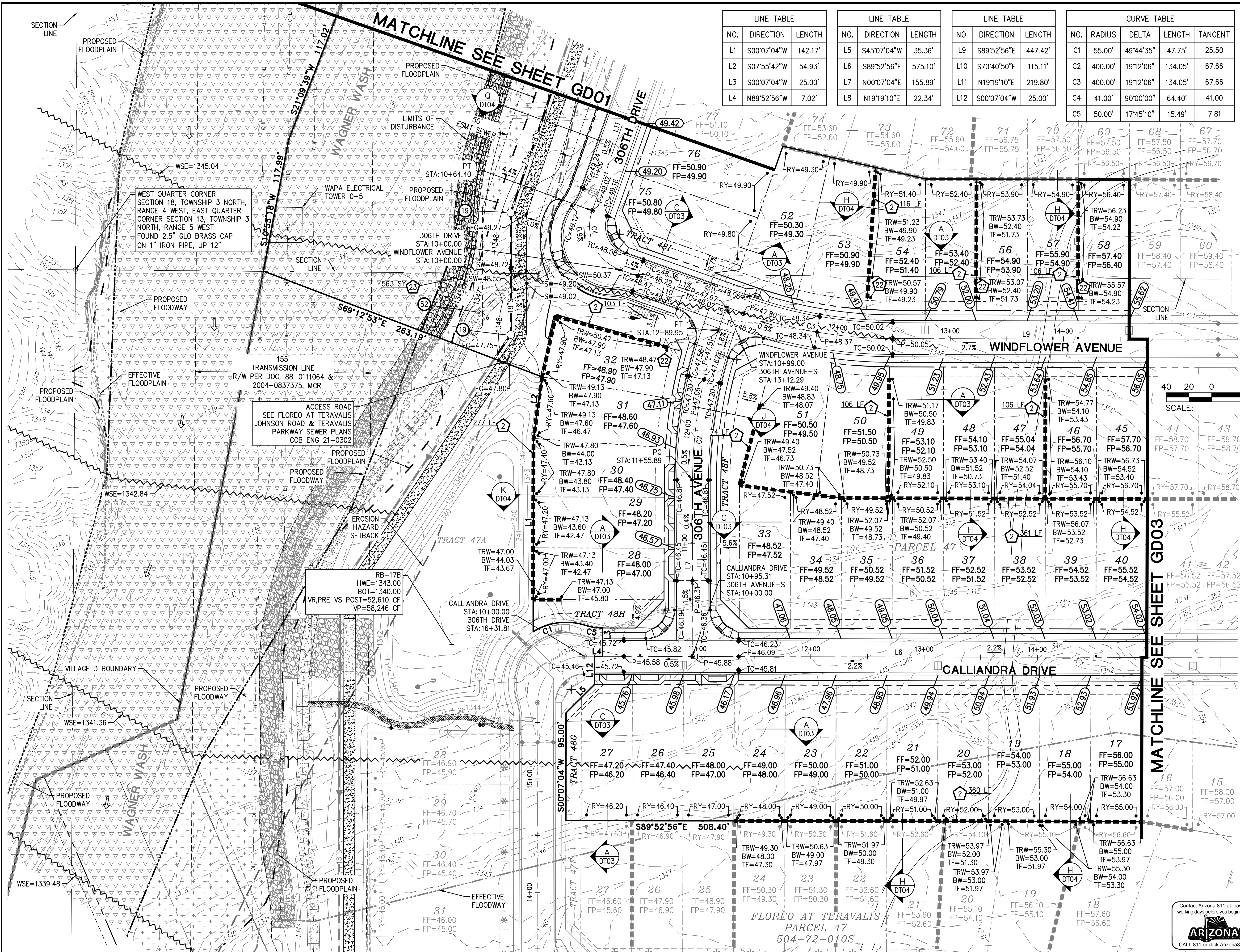

NO.	DIRECTION	LENGTH
L1	S00°07'04"W	142.17'
L2	S07°55'42"W	54.93'
L3	S00°07'04"W	25.00'
L4	N89°52'56"W	7.02'

NO.	DIRECTION	LENGTH
L5	S45°07'04"W	35.36'
L6	S89°52'56"E	575.10'
L7	N00°07'04"E	155.89'
L8	N19°19'10"E	22.34'

NO.	DIRECTION	LENGTH
L9	S89°52'56"E	447.42'
L10	S70°40'50"E	115.11'
L11	N19°19'10"E	219.80'
L12	S00°07'04"W	25.00'

CURVE TABLE				
NO.	RADIUS	DELTA	LENGTH	TANGENT
C1	55.00'	49°44'35"	47.75'	25.50
C2	400.00'	19°12'06"	134.05'	67.66
C3	400.00'	19°12'06"	134.05'	67.66
C4	41.00'	90°00'00"	64.40'	41.00
C5	50.00'	17°45'10"	15.49'	7.81

- PAVING CONSTRUCTION NOTES**
- 19 ADJUST MANHOLE FRAME & COVER PER MAG STD 2 EA DTL 422 AND COB DTL 41260.
 - 52 CONSTRUCT 10' PRIVATE LANDSCAPE SIDEWALK 1136 SF PER MAG STD DTL 230.
- GRADING CONSTRUCTION NOTES**
- 2 CONSTRUCT RETAINING WALL, ELEVATION SHOWN 1715 LF ON PLANS. REFER TO STRUCTURAL PLAN BY OTHERS.
 - 22 STEP RETAINING WALL PER RETAINING WALL STEP 4 EA DETAIL SHEET DT04.
 - 23 PLACE LOOSE ANGULAR LAUNCHABLE RIP-RAP PER MAG SPEC SECTION 220; D50=12"; ON 6" THICK GRANULAR, ANGULAR, CRUSHED STONE BEDDING. SEE DETAIL Q ON DT04.

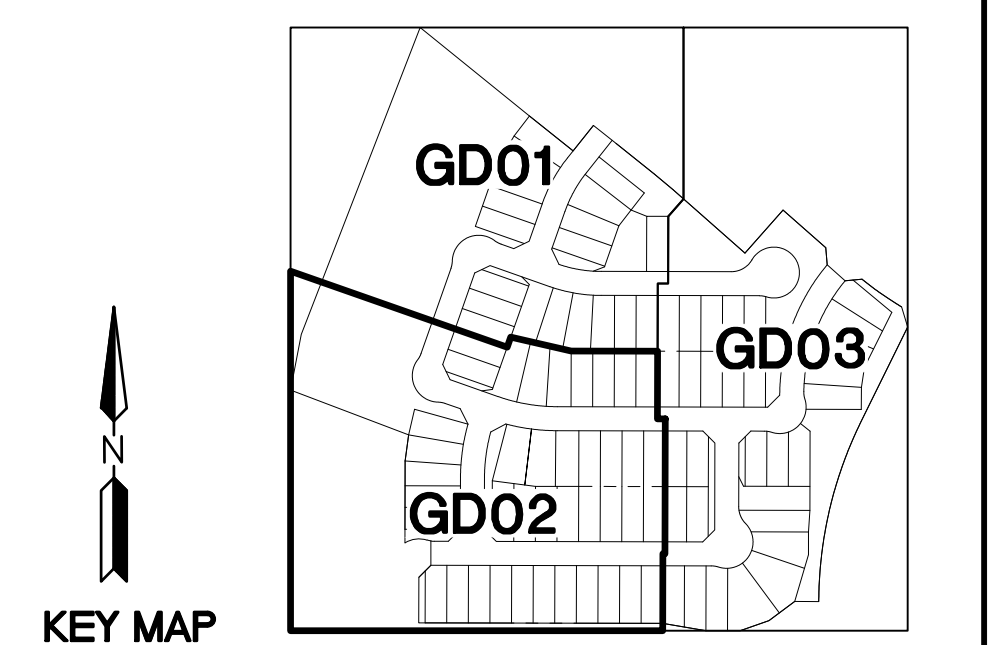
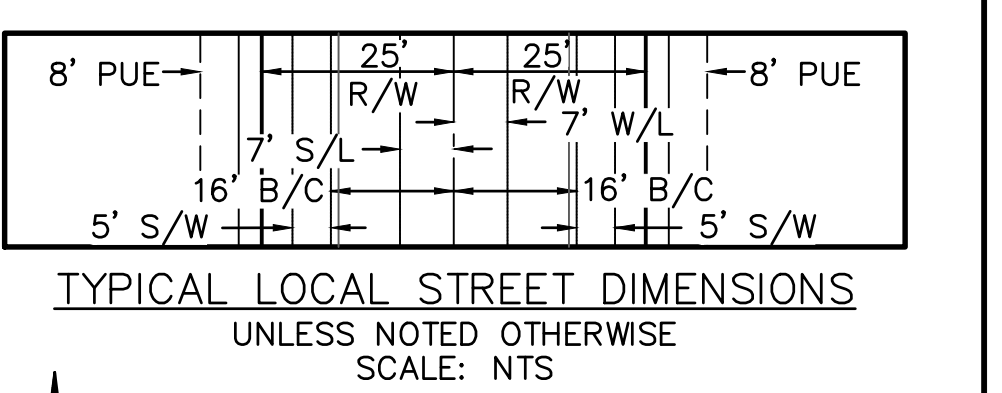

PLAN NAME
**FLOREO AT TERAVALIS
PARCEL 48
GRADING PLAN**

ENGINEER INFORMATION
HILGARTWILSON

COB PERMITTING APPROVED SEAL
COB ENGINEERING APPROVED SEAL

AS-BUILT SEAL
DESIGN SEAL

ORIGINAL PLAN DATE
NOV 2022

PROJECT NUMBER
1175

LATEST REVISION DATE
EXPIRES 12/31/23

SHEET NUMBER
GD02

SHT. OF 8
7 OF 8

COB PLAN TRACKING #
ENG-21-0595

COB PERMIT #



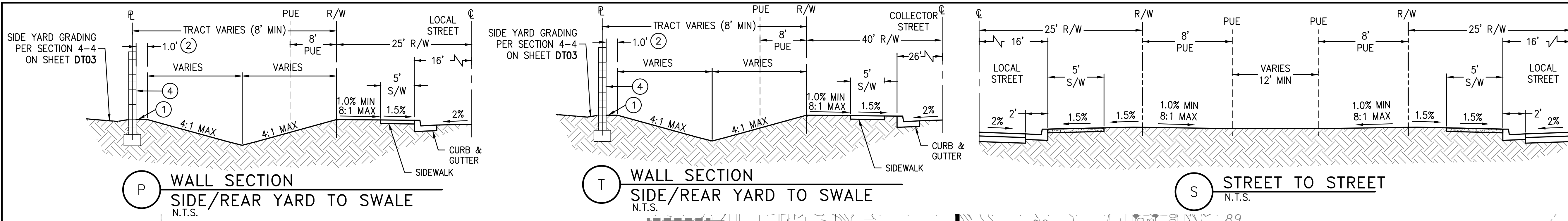

- PAVING CONSTRUCTION NOTES**
- 40 CONSTRUCT 5' PRIVATE LANDSCAPE SIDEWALK PER MAG STD DTL 230. 1955 SF
- GRADING CONSTRUCTION NOTES**
- 1 CONSTRUCT TWO CHAMBER DRYWELL; DETAIL PER COB STD DTL B-501. RIM ELEVATION 0.3FT ABOVE BASIN BOTTOM. A MINIMUM OF 20' FROM HEADWALL. LOCATION NOTED IS TO CENTER OF INTERCEPTOR. 2 EA
 - 22 CONSTRUCT RETAINING WALL. ELEVATION SHOWN ON PLANS. REFER TO STRUCTURAL PLAN BY OTHERS. 647 LF
 - 22 STEP RETAINING WALL PER RETAINING WALL STEP 4 DETAIL SHEET DT04. 4 EA

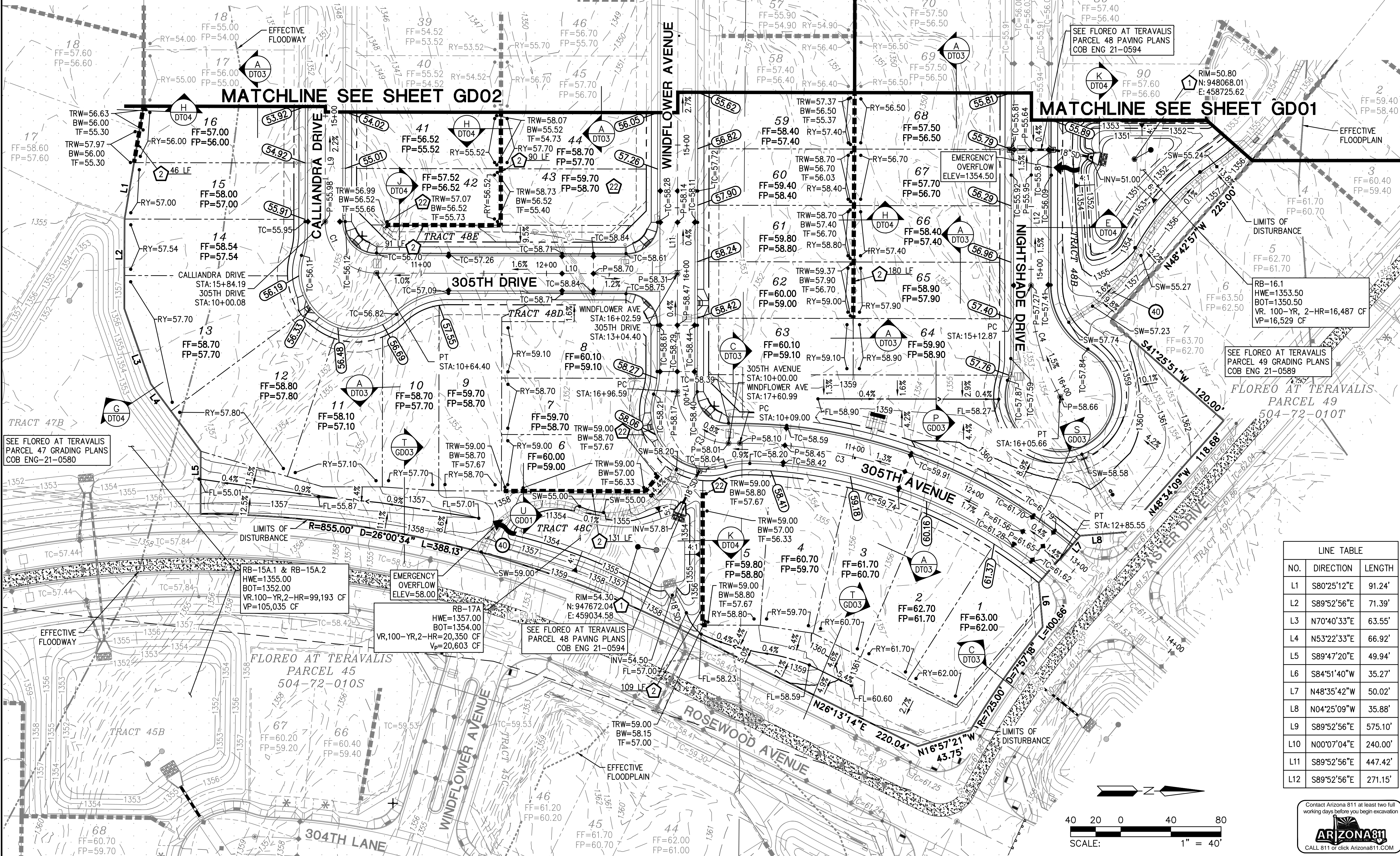

CURVE TABLE

NO.	RADIUS	DELTA	LENGTH	TANGENT
C1	41.00'	90°00'00"	64.40'	41.00'
C2	41.00'	90°00'00"	64.40'	41.00'
C3	400.00'	39°36'47"	276.55'	144.06'
C4	180.00'	29°32'12"	92.79'	47.45'

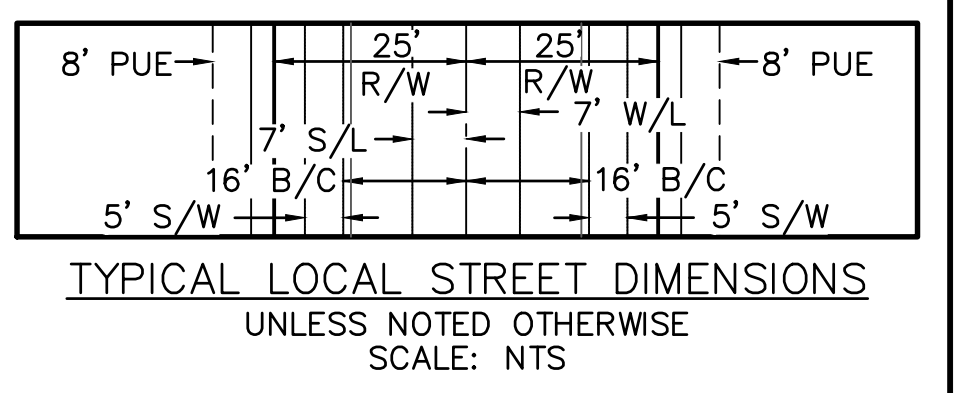

LINE TABLE

NO.	DIRECTION	LENGTH
L1	S80°25'12"E	91.24'
L2	S89°52'56"E	71.39'
L3	N70°40'33"E	63.55'
L4	N53°22'33"E	66.92'
L5	S89°47'20"E	49.94'
L6	S84°51'40"W	35.27'
L7	N48°35'42"W	50.02'
L8	N04°25'09"W	35.88'
L9	S89°52'56"E	575.10'
L10	N00°07'04"E	240.00'
L11	S89°52'56"E	447.42'
L12	S89°52'56"E	271.15'

PLAN NAME
**FLOREO AT TERAVALIS
PARCEL 48
GRADING PLAN**

ENGINEER INFORMATION
HILGARTWILSON

COB PERMITTING APPROVED SEAL
COB ENGINEERING APPROVED SEAL

AS-BUILT SEAL
DESIGN SEAL
[Signature]
23227
DAVID W. GEORGE
REGISTERED PROFESSIONAL ENGINEER
EXPIRES 12/31/23

ORIGINAL PLAN DATE: NOV 2022
LATEST REVISION DATE: _____

PROJECT NUMBER: 1175
SHEET NUMBER: **GD03** SHT. 8 OF 8

COB PLAN TRACKING # _____
ENG-21-0595
COB PERMIT # _____

Copyright HilgartWilson - This plan document set is the sole property of HilgartWilson. No alterations to these plans, other than adding "as-built" information, are allowed by anyone other than authorized HilgartWilson employees.

